

TS-46 Sensing Edge

Medium profile, pressure sensitive safety edges with a crimp-on mounting, some compliance before actuation, and 3/4" overtravel

Tapeswitch **TS-46 Sensing Edges** are general purpose, medium profile, pressure sensitive safety edges. They have some compliance before activation, eliminating nuisance tripping, and provide about 3/4" of overtravel cushioning after activation. These safety edges also exhibit excellent side activation. Mounting is in crimpable aluminum channel (flat or angle), which is more tamper-resistant than snap-in channel.

The Santoprene TPE housing is resistant to water, oil, hydraulic fluids, and coolants. The internal switching element is rated for 3 million operations at any point. All TS-46 Pressure Sensitive Sensing Edges are supplied with [4-lead fail-safe](#) wiring and are compatible with Tapeswitch [Safety Controllers](#).

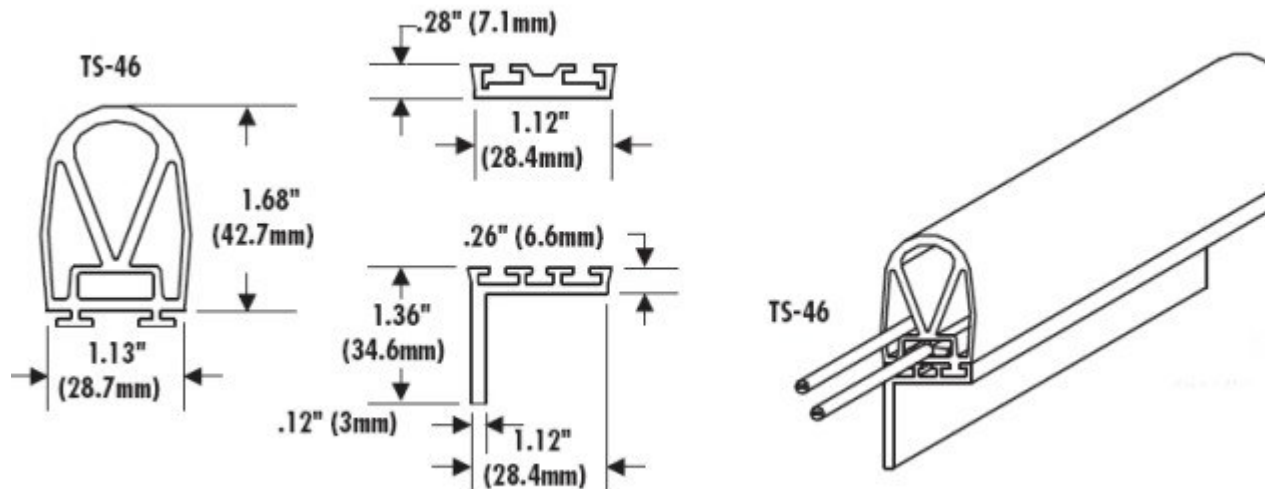

Show me a **TS-46** in
["Drawing"](#) ["Black"](#) ["Red"](#) ["Yellow"](#)

Features & Benefits

- Compliance before activation eliminates nuisance tripping
- 3/4" over travel provides cushioning after activation
- Excellent side activation properties
- [4-lead fail-safe](#) wiring is standard

Typical Applications

- Obstruction detection on power operated doors, gates, and stage lifts
- Collision detection on moving conveyors or platforms
- General applications for small sensing bumpers

Specifications for TS-46 Sensing Edges

Actuation Force	10 lbs (44 N) nominal
Overtravel	0.75" (19 mm) after activation
Recommended Voltage & Current	28 Vac or Vdc at 1.0 amps max.
Lead Wiring	2 x 20/2 AWG, Dri-Run, 72" long, 3/16" dia.
Exterior Housing	Santoprene TPE
Available Lengths	6 in to 16 ft
Environment	IP67, -30 to 170°F (-34 to 77 °C)
Mounting Options	Aluminum crimpable channel (flat or angle)

* The TS-46 has the same properties as the TS-48, but has a different mounting style.