

TP-2 & TP-4 Touchpads

The **TP Touch Pad** product line consists of normally-open, press-to-activate switches that are highly water resistant and easily mountable using a frame or adhesive. Custom touchpads are available in five different colors and with logos, text or graphics.



Features & Benefits

- Large active area of 4 or 16 square inches
- Tolerate high pressure washdowns
- Rated for outdoor applications
- Sensitive 5 lb activation force
- Long life, millions of operations
- Custom colors, graphics, text, and logos

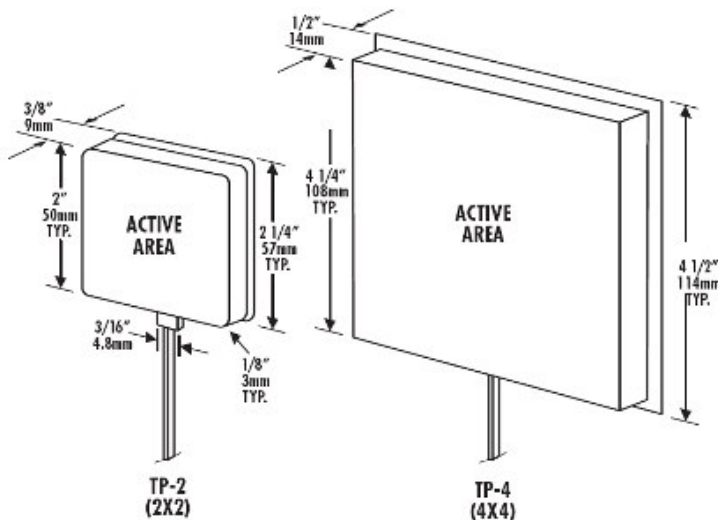

Applications

- Machine operation
- Machine stop switch
- Wall mounted door switch
- Handicap access control
- Any application requiring a large switch

Specifications for TP-2 & TP-4 Touch Pads

Actuation Force	5 lbs nominal (custom actuation force available)
Exterior Housing	PVC
Standard Sizes	2" x 2" (51 mm x 51 mm) 4" x 4" (102 mm x 102 mm)
Recommended Voltage & Current	24 Vac or Vdc at 1.0 amps max.
Environment	Watertight, 0 to 122 °F (-18 to 50 °C)
Colors	Black (custom colors available)

Touchpads with custom sizes and shapes can be manufactured to suit your individual application requirements.

Contact our Customer Service/Technical Sales Support Department for help in selecting the correct product for your specific application at **1-800-234-8273** or [Click here to email us](#).