



B-Series Photo-Electric Light Curtain Systems Technical Manual

WARNING

Tapeswitch photo-electric safety systems are intended to protect operators working at or near dangerous machinery. They can only perform this function if they are correctly fitted to a suitable machine. It is essential that the full contents of this manual and all the international documents referred to herein are fully understood before any attempt at installation is made. If in doubt, contact Tapeswitch Corporation.

IMPORTANT

This manual must accompany the product throughout its working life. Those persons responsible for the product must ensure that all persons involved in the installation, commissioning, operation, maintenance and servicing of the product have access to all the information supplied by the manufacturers of the machine and its safety system.

TABLE OF CONTENTS

1.0	GENERAL	
1.1	INTRODUCTION	4
1.2	PRODUCT APPLICATION	4
	1.2.1 <i>Typical Applications</i>	4
	1.2.2 <i>Suitability</i>	4
1.3	PRODUCT STANDARDS	5
1.4	PRODUCT FEATURES	5
	1.4.1 <i>Safety Integrity</i>	5
	1.4.2 <i>Ease of Installation</i>	5
	1.4.3 <i>Protection from Environment</i>	5
1.5	PRODUCT RANGE	5
	1.5.1 <i>General</i>	5
	1.5.2 <i>Detection Capability</i>	6
	1.5.3 Protected Heights	6
	1.5.4 Accessories	6
	1.5.4.1 <i>Mirror Units</i>	6
	1.5.4.2 <i>Mounting Stands</i>	8
1.6	ORDERING INFORMATION	8
	1.6.1 <i>Light Curtains</i>	8
	1.6.2 <i>Cable Options</i>	9
	1.6.3 <i>Interface and Programming Units</i>	9
2.0	TECHNICAL DESCRIPTION	
2.1	CURTAIN	9
2.2	COMMUNICATIONS	10
2.3	TEST INPUT	10
2.4	INDICATORS	11
3.0	INSTALLATION	
3.1	GENERAL	12
3.2	MECHANICAL INSTALLATION	12
	3.2.1 <i>General</i>	12
	3.2.2 <i>Curtain Dimensions</i>	14
	3.2.3 <i>Separation Distance</i>	15
	3.2.4 <i>Optical Alignment</i>	17
	3.2.5 <i>Reflective Surfaces</i>	17
	3.2.6 <i>Systems in Close Proximity</i>	18
	3.2.7 <i>Mounting Brackets</i>	18
3.3	ELECTRICAL INTERFACE, OPERATION, AND INSTALLATION	21
	3.3.1 <i>General</i>	21
	3.3.2 <i>Emitter Unit</i>	21
	3.3.2.1 <i>General</i>	21
	3.3.2.2 <i>Test Input</i>	22
	3.3.3 <i>Receiver Unit</i>	22
	3.3.3.1 <i>General</i>	22
	3.3.3.2 <i>Operation</i>	23
	3.3.3.3 <i>Safety Outputs</i>	23
	3.3.3.4 <i>Serial Communications</i>	24
3.4	INITIAL CHECKING AND ALIGNMENT	24

4.0	INTERFACE AND AUXILIARY UNITS	
4.1	GENERAL	25
	4.1.1 <i>Methods of Interfacing</i>	25
5.0	PERIODIC CHECKING, SERVICING, AND MAINTENANCE	
5.1	PERIODIC CHECKING	27
	5.1.1 <i>Commissioning Checks</i>	27
	5.1.2 <i>6 or 12 Month Periodic Checks</i>	27
	5.1.3 <i>Daily/Setting Examination</i>	28
	5.1.4 <i>Checking Detection Capability</i>	28
5.2	SERVICING	29
5.3	MAINTENANCE	29
6.0	TECHNICAL SPECIFICATIONS (B-Series Emitter & Receiver)	30
	APPENDIX A: BSRSA INTERFACE UNIT	31
	APPENDIX B: BSRUA-2 INTERFACE UNIT	37
	APPENDIX C: SRUB INTERFACE UNIT	45
	APPENDIX D: SRUS INTERFACE UNIT	51
	APPENDIX E: C6 MULTIFUNCTION INTERFACE CONTROLLER	55
	APPENDIX F: BC-1 BLANKING INTERFACE CONTROLLER	56
	APPENDIX G: BPU-2 BLANKING PROGRAMMING UNIT	57
	APPENDIX H: GDC-1 24VDC POWER SUPPLY	58
	APPENDIX I: LAT LASER ALIGNMENT TOOL	59

1.0 GENERAL

1.1 INTRODUCTION

Tapeswitch B-Series light curtains are through-beam photo-electric machine guarding devices, designed to protect operators working at or near dangerous machinery.

When correctly installed on a suitable machine, the system will detect a person (or part of a person) entering a dangerous area in the vicinity of the machine, and will signal the dangerous motion to cease before that person can reach a position where injury could occur.

Tapeswitch B-Series light curtains use infra-red technology. A curtain of infra-red light is projected across the dangerous area. Intrusion into this curtain by a person, or part of a person will be detected by the system. This will cause safety output signals to be generated which will stop the dangerous motion of the machine.

B-Series systems are fully self-monitoring and meet or exceed worldwide requirements for safeguarding devices used on industrial machines.

WARNING

The information in this manual relates to the use of the basic B-Series light curtain, to provide a basic safety switching device.

In some applications, a B-Series light curtain may be used together with other Tapeswitch equipment to provide additional functions and features. The additional information necessary for the correct use of a B-Series light curtain when used with other Tapeswitch equipment is provided within this manual.

In such cases, some installation parameters, notably the mounting position of the light curtain in relation to the dangerous part of the machine, can be affected and close attention must be paid to all the information supplied with all equipment.

INTERNATIONAL CONSIDERATION: The heritage of the Tapeswitch B-Series system is strongly grounded in international commerce and standards. They were developed by Tapeswitch Ltd., of Chorley, England. Both Tapeswitch Ltd. and Tapeswitch U.S. are part of Indel Corporation, a private U.S industrial group. The B-Series product line was developed to meet published and proposed safety standards for the United States, Germany, England, Finland, and Sweden, as well as the common market unified standard. B-Series systems are manufactured both in England and the United States. Tapeswitch B-Series products have been independently third party tested to IEC 61496 by BG, and are certified to this standard (CE approval/certification). Contact Tapeswitch for more details.

Tapeswitch can provide additional assistance to customers wishing to use B-Series guards in international applications. Some foreign language technical manuals are available.

1.2 PRODUCT APPLICATION

1.2.1 TYPICAL APPLICATIONS

The high level of safety integrity provided by the B-Series light curtains makes them suitable for use on many types of machines, including some of those presenting the highest risk. Typical applications are:

- Pinch point protection
- Power presses
- Filter presses
- Robot assembly and welding cells
- Die casting machines
- Injection molding machines
- Special purpose machinery
- General automated machinery

1.2.2 SUITABILITY

The most important factors affecting the suitability of a photo-electric guarding device relate to the machine control system. The machine control system must satisfy the following fundamental requirements:

- (a) The dangerous motion of the machine must be electrically controllable.
- (b) The machine response/stopping performance must be adequate and consistent.
- (c) It must be possible to stop the dangerous motion of the machine at any point in its operation.

(d) The control system as a whole must be constructed to provide an appropriate category of safety integrity as defined in EN954-1 'Safety of machinery: Principles for the design of safety related control systems'. The appropriate category of safety integrity should be determined by performing a risk assessment as described in EN1050 'Safety of machinery: Risk assessment'.

Additional factors which may preclude the use of photo-electric devices include:

(e) Risk of injury from thermal or other radiation.

(f) An environment likely to adversely affect the efficiency of the photo-electric safety system.

(g) A tendency for the machine to eject materials or components which are either potentially hazardous to the operator or which interfere with the operation of the safety device.

Photo-electric safety systems may be suitable if additional measures are taken to control the risks associated with factors (e) to (g), e.g. local fixed guards to control ejection.

1.3 PRODUCT STANDARDS

Tapeswitch B-Series light curtains meet the requirements of the international standard IEC61496 'Safety of machinery: Electro-sensitive protective equipment' Parts 1 and 2.

Each basic B-Series light curtain is a complete Active Opto-electronic Protective Device or AOPD. This means that the infra-red light used for detection purposes is generated by the system itself. An AOPD is a particular type of Electro-Sensitive Protective Equipment or ESPE. Both of these terms are defined in IEC61496 Parts 1 and 2. Part 1 applies to all types of ESPE and Part 2 covers the particular requirements for AOPDs.

B-Series light curtains are Type 4 devices as defined by this standard, which means that they are fully self-monitoring, and are, therefore, suitable for use as part of safety-related control systems of category 4 (or below) as defined by EN954.

WARNING

The B-Series light curtain, in itself, does not guarantee a category 4 safety system has been achieved. Other factors such as stopping time, separation distance, and proper interface, all contribute to the overall safety level. A safety system is only as strong as its weakest link and in order to maintain a category 4 system, all devices in the safety system must be category 4.

1.4 PRODUCT FEATURES

1.4.1 SAFETY INTEGRITY

- Diverse redundancy.
- Solid State safety outputs.
- Fully self-monitoring.
- Test input for system check.
- Variety of interface units (optional).

1.4.2 EASE OF INSTALLATION

- No interconnection between curtain units.
- 24VDC operation.
- Adjustable mounting brackets supplied.

1.4.3 PROTECTION FROM ENVIRONMENT

- Immune to ambient light.
- Immune to xenon beacons and strobes.
- High level of immunity to vibration.
- High level of electromagnetic immunity.
- Enclosures sealed to IP65.
- Polyester powder coating.

1.5 PRODUCT RANGE

1.5.1 GENERAL

The B-Series light curtains are available in a range of different protected heights and detection capabilities. These two parameters are known by many other names and therefore it may be useful to define them here, as they are intended to be used in this manual. To make this clearer it is also necessary to define two further parameters, detection zone and operating range:

Detection Zone: This is the actual curtain of infra-red light generated between the emitter and receiver units within which an appropriately dimensioned object will be reliably detected and, for the B-Series, can be considered to be a two dimensional, rectangular plane (see *Figure 1*).

Operating Range: One dimension of the detection zone rectangle is given by the distance between the emitter and receiver units. This is the operating range (see **Figure 1**).

Protected Height: The other dimension of the detection zone rectangle is commonly known as the protected height. The word “height” has been adopted in the latest standards for this equipment because most curtains are mounted vertically. The protected height is often related to, but is not the same as, the length of the emitter and receiver units (see **Figure 1**).

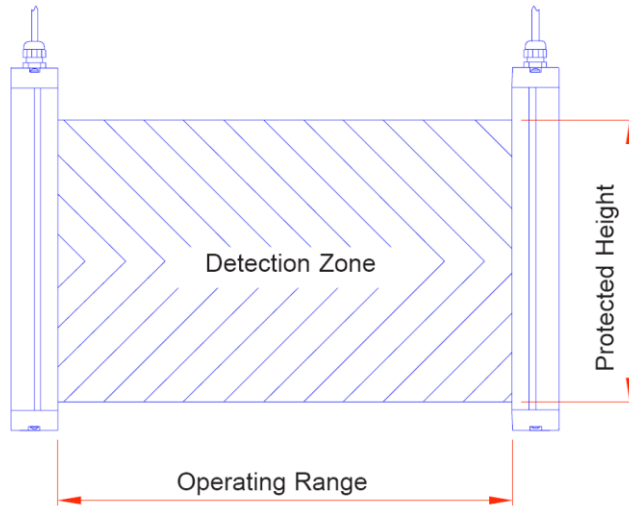

Figure 1

Detection Capability: This is the minimum dimension of an opaque object which will be reliably detected anywhere within the detection zone.

NOTE: The spacing or pitch of the beams or lenses in a light curtain is not the same as the detection capability. The detection capability is always greater than the spacing or pitch. Spacing or pitch should not be used in the calculation of separation distances (see **Figure 2**).

1.5.2 DETECTION CAPABILITY

B-Series light curtains are available with detection capabilities of 14mm, 30mm, or 70mm.

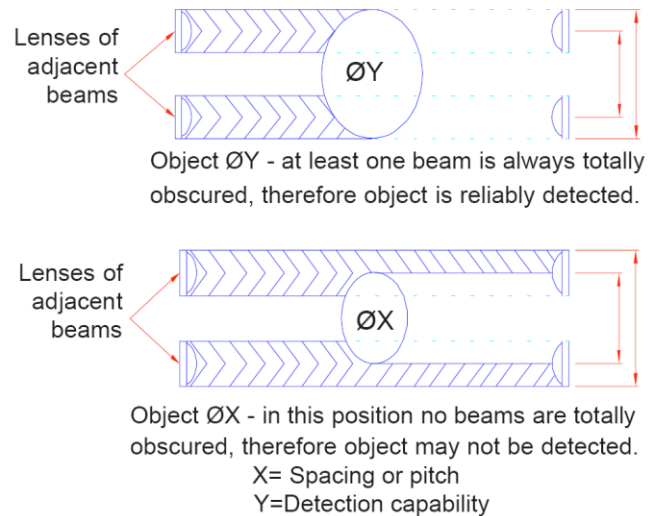

Figure 2

1.5.3 PROTECTED HEIGHTS

B-Series light curtains are available with nominal protected heights as follows:

Detection Capability	Nominal protected heights (in. mm and inches)
14mm (1/2in.)	200-300-400-600-800-900-1000-1200mm (8-12-16-24-32-36-40-48 inches)
30mm (1-3/16in.)	200-300-400-600-800-900-1000-1200-1400-1600mm (8-12-16-24-32-36-40-48-56-64-72 inches)
70mm (2-3/4in.)	600-800-1000-1200-1400-1600-1800mm (24-32-40-48-56-64-72 inches)

The minimum separation distance is 0.5m.

Note:

The actual protected height is 8mm greater than the nominal protected height.

1.5.4 ACCESSORIES

1.5.4.1 Mirror Units

A range of mirror units are available to enable a single curtain to be used to guard two or three sides of a machine or to avoid structural obstructions.

The mirror assembly consists of a high quality silver-backed glass mirror adhesively attached to a length of extruded aluminum. Two pivot brackets are bolted to the aluminum extrusion and can be adjusted anywhere along the length for mechanical attachment. The actual length of the mirror is 4 inches (1000mm) larger than the active curtain length to accommodate a wide tolerance for height alignment. All of the necessary hardware is supplied to facilitate mounting to the mounting/floor stands. The dimensions of the pivot brackets, extruded aluminum and overall mirrors are shown below in millimeters.

Pivot Bracket

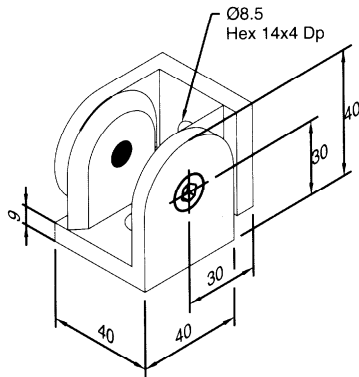

Extrusion Dimensions

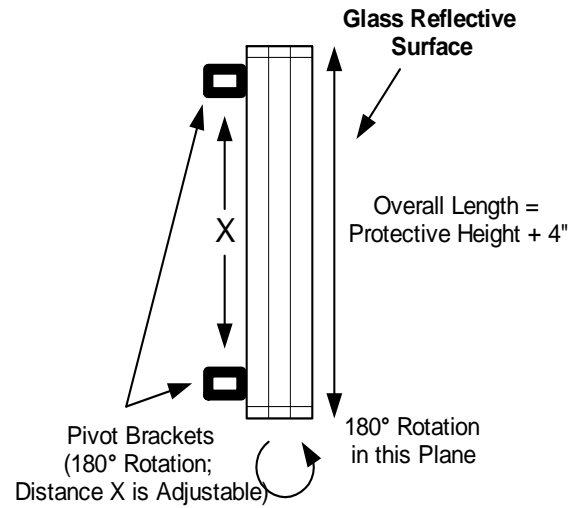
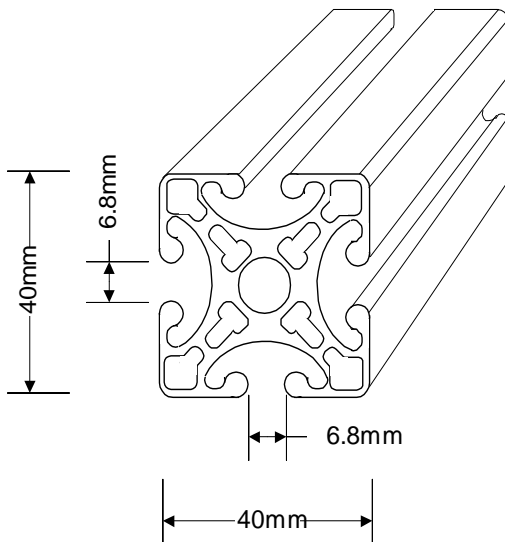

Supplied with:

1. 1-40mm x 40mm extrusion, 100mm larger than protective height.
2. 1-silver backed mirror, 100mm larger than protective height.
3. 2-pivot joints.
4. 2-40mm x 40mm end covers.
5. 4-5mm T slot nuts.
6. 4-#12 flat washers.
7. 4-5mm spring washers.
8. 4-5mm x 5/8 hex bolts.

Curtain Lengths	Mirror Assembly Length	P/N
200mm - 8"	300mm - 12"	0960
300mm - 12"	400mm - 16"	0961
400mm - 16"	500mm - 20"	0962
600mm - 24"	700mm - 28"	0963
800mm - 32"	900mm - 36"	0964
900mm - 36"	1000mm - 40"	0965
1000mm - 40"	1100mm - 44"	0966
1200mm - 48"	1300mm - 52"	0967
1400mm - 56"	1500mm - 60"	0968

For units greater than 56 inches, custom mirrors are available.

1.5.4.2 Mounting Stands

Floor mounting stands are available for use where the guard cannot be mounted directly to the machine.

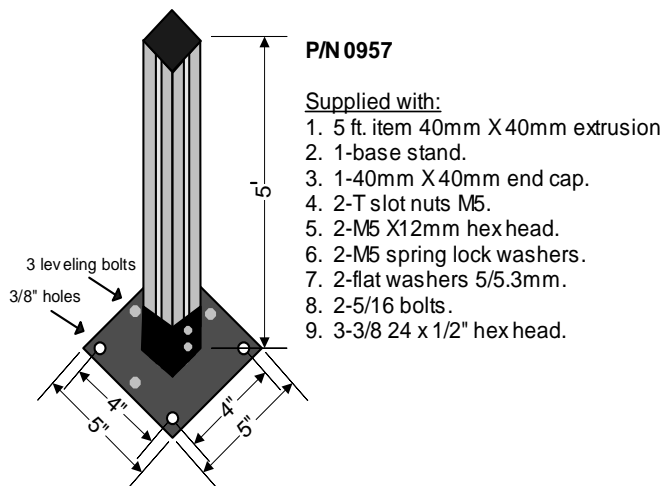

The mounting stand set includes a floor-mounted base into which the 5-foot mounting post can be secured. The floor base is steel and can be permanently mounted to the floor surface with the pre-drilled mounting holes. The post is extruded aluminum with slots to allow the light curtain to be positioned anywhere along its length. The mounting stands are supplied with all of the necessary hardware to facilitate mounting a standard B-Series light curtain. Leveling bolts allow for minor adjustments to the floor stand orientation.

1.6 ORDERING INFORMATION

1.6.1 LIGHT CURTAINS

Part numbers on the following table should be used for ordering. The units will be marked according to the model as follows:

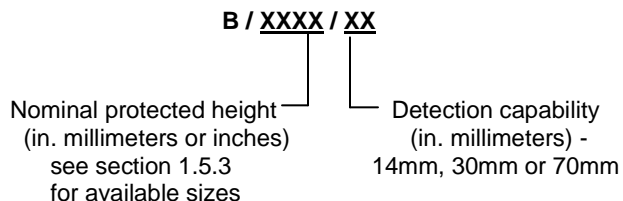

Model Number	Part Number
B/8"(208mm)/30	0901
B/12"(308mm)/30	0902
B/16"(408mm)/30	0903
B/24"(608mm)/30	0904
B/32"(808mm)/30	0905
B/36"(908mm)/30	0906
B/40"(1008mm)/30	0907
B/48"(1208mm)/30	0908
B/56"(1408mm)/30	0909
B/64"(1608mm)/30	0910
B/72"(1808mm)/30	0911
B/8"(208mm)/14	0912
B/12"(308mm)/14	0913
B/16"(408mm)/14	0914
B/24"(608mm)/14	0915
B/32"(808mm)/14	0916
B/36"(908mm)/14	0917
B/40"(1008mm)/14	0918
B/48"(1208mm)/14	0919
B/24"(608mm)/70	0921
B/32"(808mm)/70	0922
B/40"(1008mm)/70	0923
B/48"(1208mm)/70	0924
B/56"(1408mm)/70	0925
B/64"(1608mm)/70	0926
B/72"(1808mm)/70	0927
B4	0928
B3	0929
B2	0930

1.6.2 CABLE OPTIONS

Cable assemblies are used to connect the B-Series emitter and receiver units to a controller or machine. The emitter has a 5-wire cable and the receiver has an 8-wire cable. One end of each cable has a keyed quick-disconnect connector and the other end is unterminated. The cables are IP68 rated, and UL and CSA recognized.

Order cable options using the following part numbers:

Description	Part Number
Emitter Cable, 15ft, 5 Conductor	0972
Emitter Cable, 30ft, 5 Conductor	0973
Emitter Cable, 98ft, 5 Conductor	0976
Receiver Cable, 15ft, 8 Conductor	0974
Receiver Cable, 30ft, 8 Conductor	0975
Receiver Cable, 98ft, 8 Conductor	0977

1.6.3 INTERFACE AND PROGRAMMING UNITS

(See electrical interface and operation for technical details)

Order interface and programming units using the following part numbers:

Model	Description	Part Number
BSRSA	Wall-mounted box 110/240VAC or 24VDC	0950
BSRUA-2	DIN rail mount 110/240VAC or 24VDC	0951
SRUB	DIN rail mount 24VDC	0952
SRUS	DIN rail mount 24VDC	0949
BC-1	Combines BSRA and BPU-2	0959
C6	Wall-mounted box Multi-zone	0480
GDC1	24VDC power supply	0953
BPU-2	Blanking programmer	0954
LAT	Laser alignment tool	0956

2.0 TECHNICAL DESCRIPTION

2.1 CURTAIN

A basic B-Series light curtain consists of two units: an emitter unit and a receiver unit. Both units are identical in shape and size. The units are enclosed in a robust extruded aluminum section with reinforced composite end covers.

The emitter and receiver units together generate a curtain of infra-red light between them. This curtain is mounted in such a position in relation to the dangerous parts of a machine that a person or part of a person approaching those dangerous parts must first penetrate the curtain. This penetration is detected by the light curtain system and, by means of its output switching devices, the light curtain system causes the dangerous parts to go to a safe state (e.g. by stopping moving parts) before the person can reach them.

IMPORTANT

From the information above, it can be seen that safe use of a light curtain relies not only on the safety integrity of the curtain itself but also on its proper mechanical and electrical interfacing to the machine.

The safety integrity of the light curtain itself is the responsibility of Tapeswitch and the remainder of this section describes the features of the design by which safety integrity is ensured.

Proper mechanical and electrical interfacing of the overall system is the responsibility of the user. Comprehensive information for this purpose is provided in sections 3 and 4 of this manual.

The emitter unit contains a number of infra-red light emitting diodes (LEDs). The quantity and spacing of these LEDs depends on the protected height and the detection capability of the particular light curtain. The devices are arranged equally-spaced in an array.

The receiver unit contains a corresponding number of infra-red photodiodes similarly arranged.

Each LED and photodiode is fitted with a precision lens, which produces an evenly intense, slightly diverging beam of infra-red light from each LED and an evenly sensitive, slightly converging 'reception cone' into each photodiode. This arrangement provides a high signal-to-noise ratio and maximum operating range for the system together with ease of alignment and rejection of extraneous reflected light sources.

The function of each LED and photodiode is controlled by its own dedicated, specially-designed ASIC (Application Specific Integrated Circuit). All the circuitry necessary for the operation of an LED or photodiode is contained within this single component, resulting in a very low component count and consequent improvement in system reliability.

For each LED in the emitter unit there is a corresponding photodiode at the same relative position in the receiver unit. Each LED/photodiode pair makes a 'beam' and the curtain is made up of a number of such beams, all parallel to each other. (See **Figure 3**.)

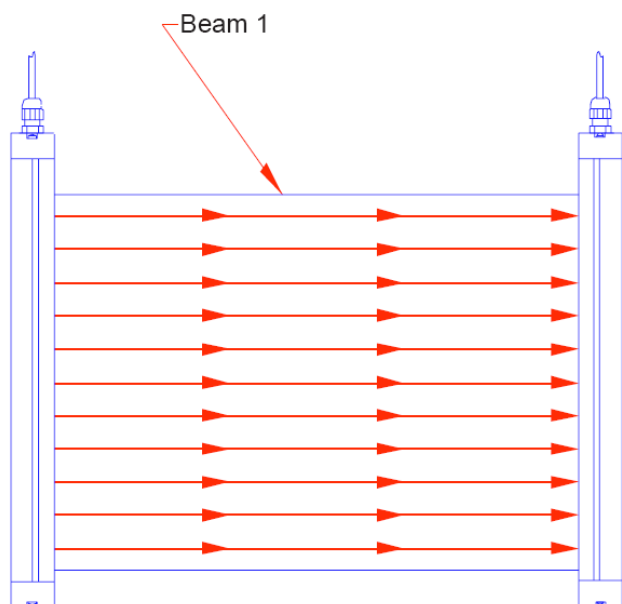

Figure 3

Only one LED and one photodiode are active at any time. The emitter unit runs independently from the receiver unit. There are no connections between the units.

The emitter unit activates each of its LEDs in turn and the receiver unit synchronizes with the emitter unit.

Each receiver ASIC, in its turn, generates an output signal which is proportional to the level of infra-red it receives from its corresponding LED. Signals from other sources, such as background lighting, are filtered out inside the ASIC.

There is one microprocessor in the emitter unit and two in the receiver unit. All three microprocessors perform exhaustive checks on their own hardware and software, prior to and during operation.

The two in the receiver unit continually communicate their results to each other such that if a fault occurs in one device the other can shut the system down.

In the receiver unit there are two independent switching channels each containing an output signal switching device (OSSD). Each of the two microcontrollers in the receiver unit controls one of these OSSDs and monitors the other.

The OSSDs are very robust solid state devices. These devices are intended to be connected directly to the machine control system, a Tapeswitch interface unit or a suitable safety relay such that if one or both of them are in the OFF state, the machine will go to or remain in a safe condition, for example, by stopping dangerous motion or by preventing dangerous motion from starting.

2.2 COMMUNICATIONS

The receiver unit incorporates a serial communications port. Various auxiliary Tapeswitch units can be connected to this port for the purposes of programming functions within the light curtain and for interrogating the system.

No equipment other than Tapeswitch brand should be connected to this port. Full instructions for the use of this port with auxiliary equipment is provided within this manual.

2.3 TEST INPUT

A pair of terminals is provided across which a pair of normally closed, volt free contacts should be connected. When these contacts are opened the emitter unit will stop scanning, forcing the OSSDs to the OFF state. This input simulates a curtain obstructed condition.

NOTE: This input is provided to allow the B-Series to be used with machine control systems which need to cycle the safety circuit prior to operation. The B-Series system itself does not require this input to be used. If this input is not used it should be jumpered and remain jumpered at all times.

2.4 INDICATORS

The receiver unit has four status indicators as shown in **Figure 4**. The emitter unit has two status indicators as shown in **Figure 5**. A description of each indicator is given in **Table 1**.

Unit	Color	Description
Emitter	Amber	Lit when power is connected to unit.
	Red	Lit steady when test input is applied. Lit flashing when emitter unit is faulty.
Receiver	Amber	Lit when power is connected to unit.
	Green	Lit when curtain is clear.
	Red	Lit brightly when curtain is obstructed. Lit dimly when the curtain is clear .
	Yellow	Lit flashing when receiver unit is faulty. Lit steady when curtain has been programmed to a state other than no blanking.

Table 1

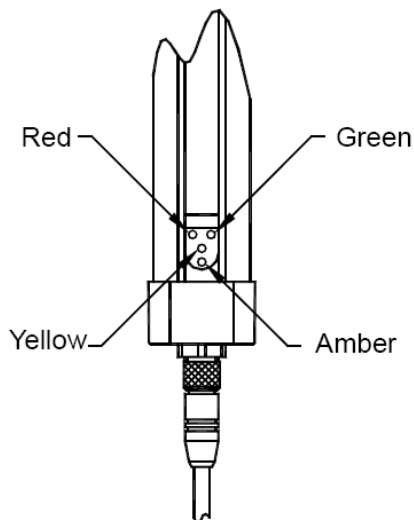

Figure 4
Receiver

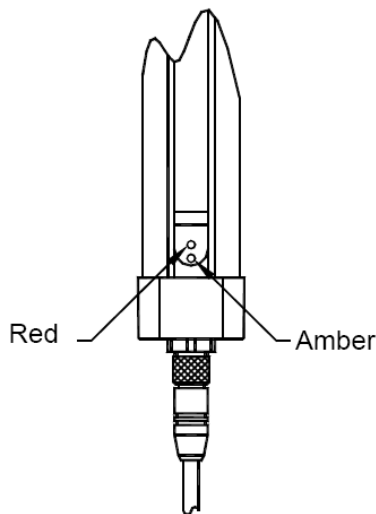

Figure 5
Emitter

3.0 INSTALLATION

3.1 GENERAL

WARNING

Tapeswitch B-Series systems are designed to protect operators working at or near dangerous machinery. They can only perform this function if they are correctly fitted and interfaced to a suitable machine. Those persons responsible for the machine must ensure that all persons involved in the installation of the photo-electric safety system have the necessary knowledge, training and experience and that they are fully aware of all laws, rules, regulations and codes of practice pertaining to their task.

The attention of the installer is drawn to following general requirements for the installation of a B-Series system:

- (a)** The dangerous motion of the machine must be electrically controllable.
- (b)** The machine response/stopping performance must be adequate and consistent.
- (c)** It must be possible to stop the dangerous motion of the machine at any point in its operation, in any operating mode.
- (d)** The control system as a whole must be designed and constructed to provide the appropriate category of safety integrity as defined in EN954 'Safety of machinery: Principles for the design of safety related control systems'. The appropriate category should be as prescribed in the relevant C type EN standard for the type of machine concerned. In the absence of such a standard, the appropriate category of safety integrity should be determined by performing a risk assessment as described in EN1050 'Safety of machinery: Risk assessment'.
- (e)** Steps must be taken to prevent access to the dangerous parts of the machine from any direction not covered by the photo-electric curtain. Such steps could include fixed or interlocking fences or screens, additional photo-electric devices or pressure sensitive mats. Similar steps should be taken to prevent a person

from standing between the curtain and the dangerous parts of the machine.

(f) No devices other than those specified in this manual should be connected to the internally-generated power supply of the system.

(g) After installation, the machine/guard system must be commissioned in accordance with the requirements of section 5.1.1 of this manual.

(h) Any covers removed during installation must be replaced as soon as possible.

(i) After the curtain has been actuated, it must not be possible for the machine to restart until a manual control has been operated. This is known as 'restart interlock'. The basic B-Series system does **not** provide this function. The function of the basic B-Series system is 'GUARD ONLY' i.e. when the curtain is clear the outputs are ON and when the curtain is broken the outputs are OFF.

3.2 MECHANICAL INSTALLATION

3.2.1 GENERAL

ANSI B11.19-1990 gives guidance on the dimensions and positioning of photo-electric safety devices fitted to industrial machines. The main considerations are described below and are illustrated in **Figure 6**.

(a) The appropriate protected height must be selected. The curtain must be of sufficient height such that access to the dangerous parts, from the direction of approach of the operator, is only possible by obstructing the curtain taking into account all possible operator positions.

(b) The correct minimum separation distance must be observed. The curtain must be mounted in the correct position in relation to the dangerous parts of the machine to take account of the stopping performance of the machine, the curtain format used and the detection capability of the curtain.

(c) Steps must be taken to prevent access to the dangerous parts from any direction not covered by the curtain and to prevent an operator from standing between the curtain and the dangerous parts without obstructing the curtain. Additional mechanical guarding will usually be necessary to achieve this.

The physical parameters affecting the positioning are the dimensions of the detection zone of the light curtain (i.e. the protected height and the range) and the minimum separation distance. These are described in the following sections.

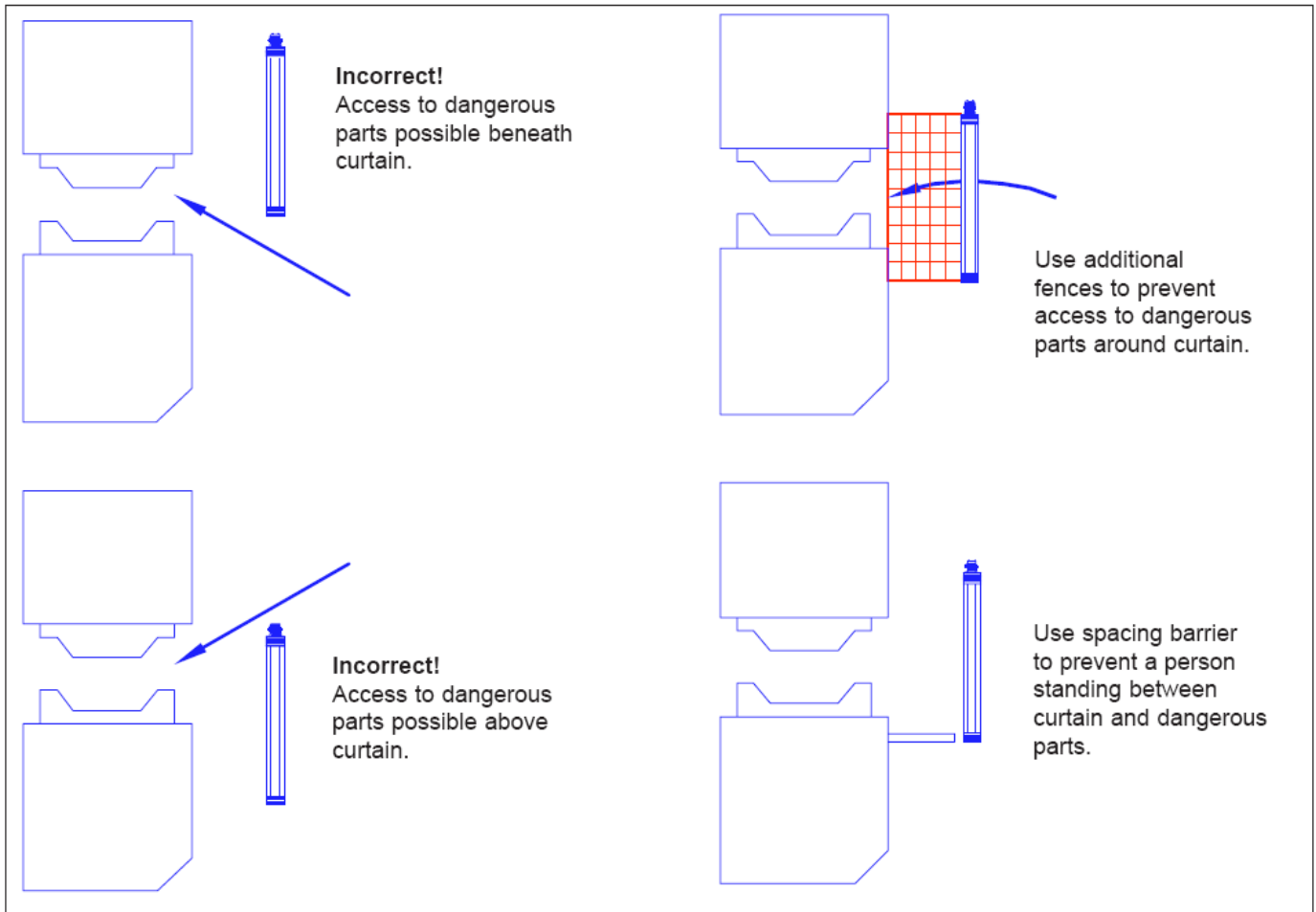

Figure 6

3.2.2 CURTAIN DIMENSIONS

The curtain dimensions are defined by the protected height and the range (i.e. the distance between the emitter and receiver units). The protected height must be selected to suit the application. The minimum range for all systems is 500 millimeters. The maximum range for systems with 14mm detection capability is 6 meters (18 feet). The maximum range for systems with 30mm or 70mm detection capability is 13 meters (43 feet).

All the dimensions relating to the curtain, for each of the B-Series systems are shown in **Figure 7**. The upper and lower boundaries of the curtain are indicated by arrows on the front window labels of each unit.

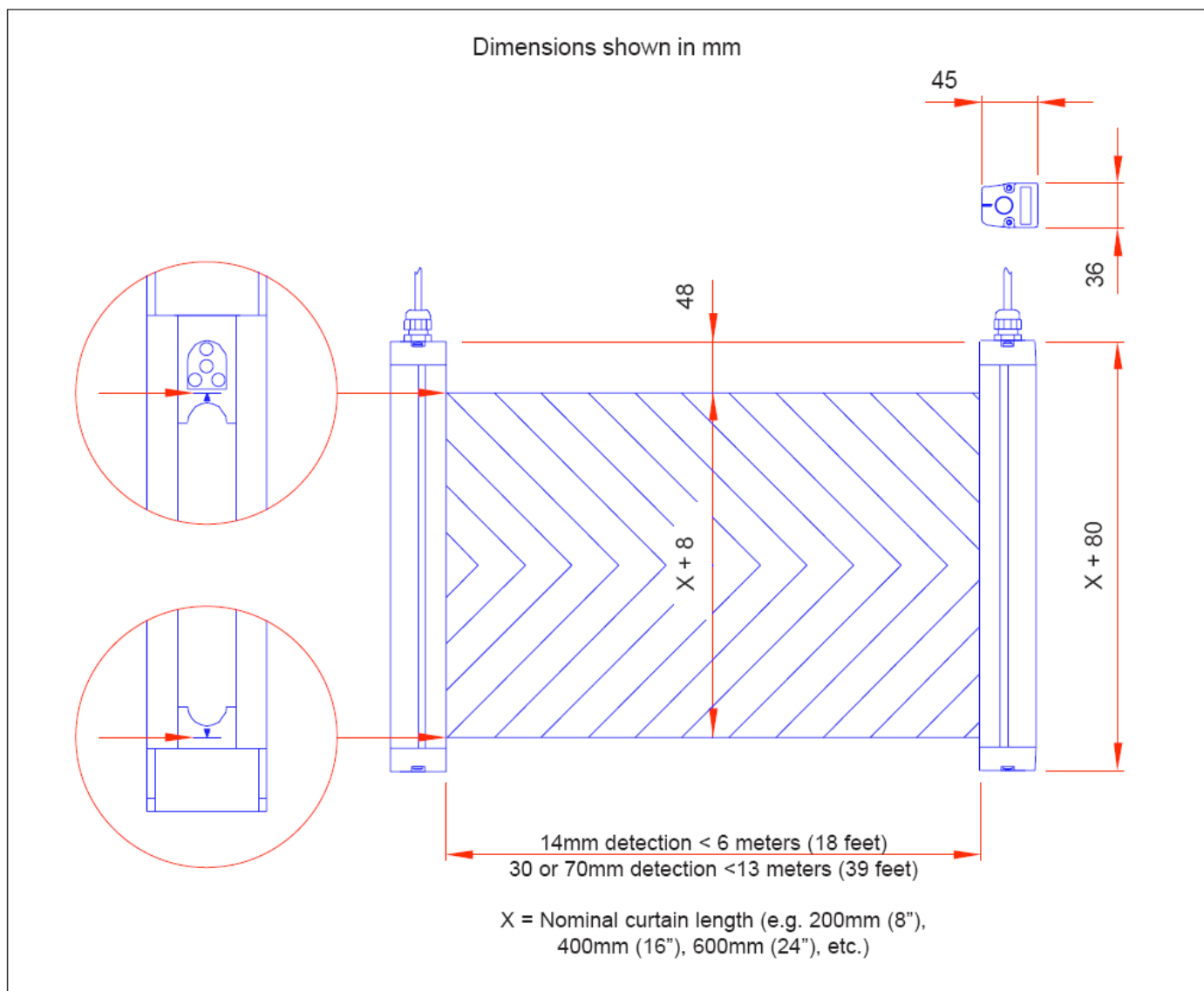

Figure 7

3.2.3 SEPARATION DISTANCE

Any machine, regardless of the efficiency of its braking system, will take a certain time to come to rest after a stop signal is generated.

The time from the instant that the curtain is broken to the instant that dangerous motion actually ceases is called the “overall system response time”. The dangerous parts will obviously continue to move during this time. The curtain must therefore be positioned at a certain minimum distance from the dangerous parts to prevent a person who has obstructed the curtain from reaching the dangerous parts before they have stopped.

This distance is the “minimum separation distance” and is defined as the distance, in the direction of approach, between the physical point at which the curtain detects an obstruction and the nearest dangerous parts.

ANSI B11.19-1990 provides guidelines on how to determine the minimum separation distance for a given application. Tapeswitch B-Series systems are primarily intended for use in normal approach format where the curtain is perpendicular to the direction of approach, although they can be used in parallel and angled approach formats.

Normal approach format is shown in **Figure 8**. For normal approach format the inner edge of the front window of each unit (i.e. the edge which is nearest to the machine) should be considered to be the point at which an obstruction is detected. See plane X as shown in **Figure 8**.

The effective sensing field of the device shall be located at a distance from the nearest recognized hazard such that the operator or others cannot reach the hazard with a hand or other body part before stopping of the motion during the hazardous portion of the machine cycle.

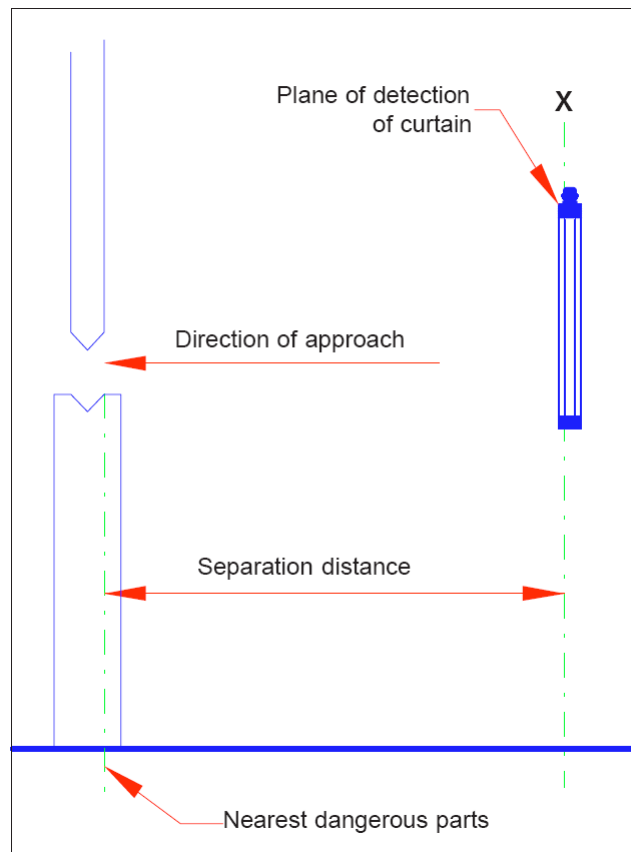

Figure 8

The minimum separation distance depends on the application. The following formula should be used when calculating this distance:

$$D_s = K \times (T_s + T_R + T_C + T_{BM}) + D_{PF}$$

where:

D_s = Minimum separation distance between the device and the nearest point of operation hazard in inches.

K = Hand speed constant.
See note.

T_s = Stop time of the machine tool measured at the final control element.

T_C = Response time of the control system.

NOTE: T_s and T_C are usually measured by a stop-time measurement device.

T_R = Response time of the presence-sensing device and its interface, if any, as stated by the manufacturer or as actually measured.

T_{BM} = Additional time allowed for the brake monitor (if used) to compensate for variations in normal stopping time.

D_{PF} = Added distance due to the penetration factor, as recommended in the illustration below. The minimum object sensitivity is stated by the manufacturer. If beam blanking or floating window features are used, these figures should be added to the object sensitivity figure before using the chart.

NOTE: The value of the hand speed constant, K , has been determined by various studies. Although these studies indicate speeds of 63 in/sec to over 100 in/sec, they are not conclusive determinations. The employer should consider all factors, including the physical ability of the operator, when determining the value of K to be used.

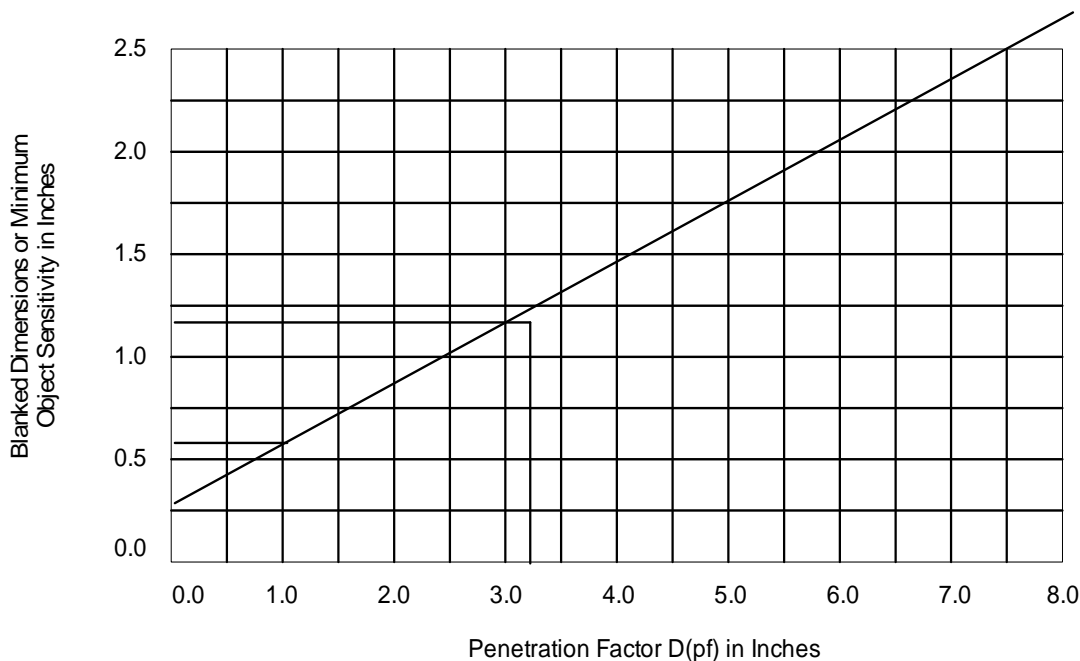

DPF	Detection
1 inches	14mm
3.1 inches	30mm
8 inches	70mm

3.2.4 OPTICAL ALIGNMENT

The emitter and receiver units should be mounted facing each other at the same height with their axes aligned. Misalignments, as illustrated in **Figure 9**, should be avoided. Tapeswitch offers a laser alignment tool to add visible assistance over longer range or when mirrors are used. See section 4 for detailed information.

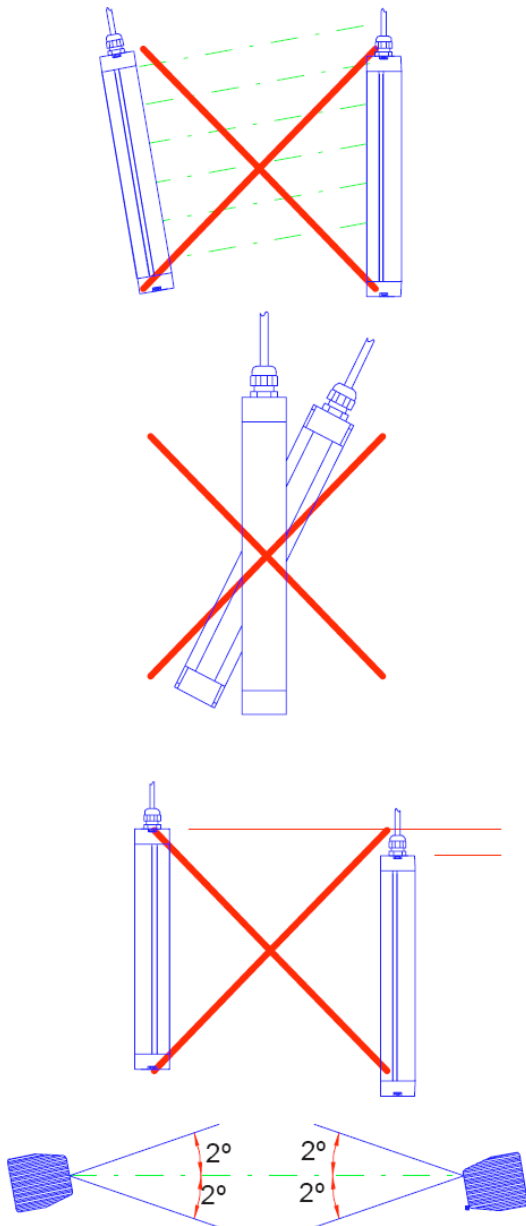

Figure 9

3.2.5 REFLECTIVE SURFACES

There should be no reflective surfaces within the 'field of view' of the curtain units. Reflective surfaces within the field of view can lead to non-detection of an obstruction. The field of view of each of the emitter and receiver units is approximately 2 degrees either side of the optical axis.

A minimum distance from the optical axis to any reflective surface must be observed. This distance depends on the actual operating distance and must take into account possible misalignment. This is illustrated in **Figure 10**. The distance should be determined as follows:

Operating distance $L < 3m$: $X < 75mm$

Operating distance $L > 3m$: $X > 0.025mm$

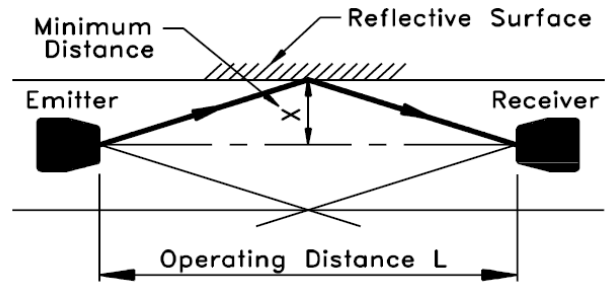

Figure 10

3.2.6 SYSTEMS IN CLOSE PROXIMITY

In order to avoid nuisance interference between adjacent systems, whenever two or more emitter-receiver pairs are used within 10 meters of each other, ensure that the front window of any unit is not within the field of view of units of the opposite type from other systems.

This can be achieved by ensuring that units of the same type are mounted facing in opposite directions. See **Figure 11**.

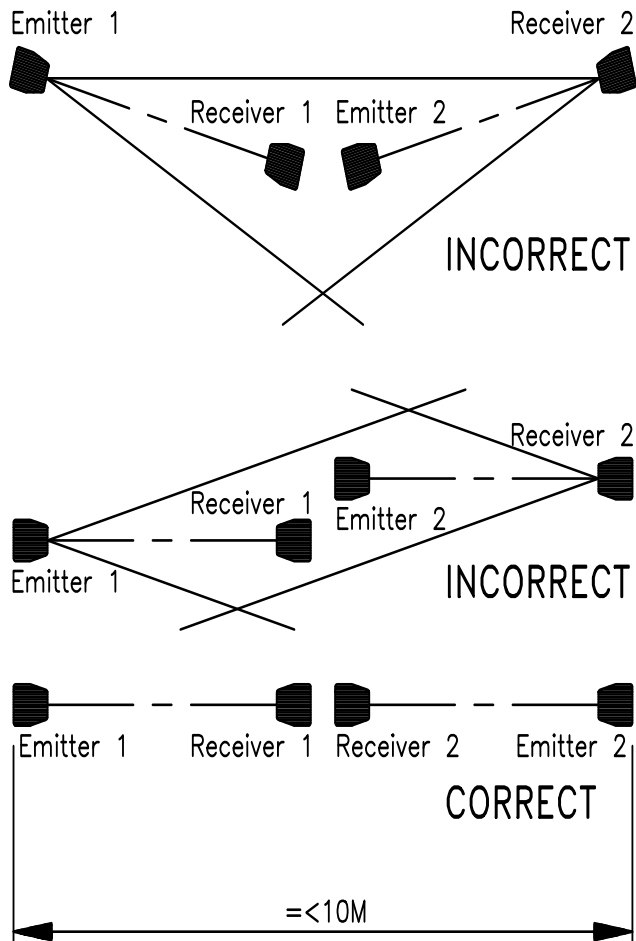

Figure 11

3.2.7 MOUNTING BRACKETS

Mounting brackets and their associated hardware are provided with the emitter and receiver units. The brackets have been specially designed to allow adjustment.

Each unit is supplied with two clamp brackets fitted, one at each end. The clamp bracket is a short piece of extruded aluminum which is designed to interlock with the unit housing extrusion and to clamp in position on the rear of the housing by means of two set screws. The set screws can be tightened or loosened with a 2mm Allen wrench, which is supplied with the unit. The clamp bracket can be slid up and down the emitter and receiver units to facilitate alternate positioning of the bracket. The clamp brackets are a tight fit on the emitter and receiver units and may require some force to slide them up and down on. The clamp bracket dimensions are shown in **Figure 12**.

The clamp brackets can be moved to any position over the length of the unit, but it is recommended that they be kept in the supplied position.

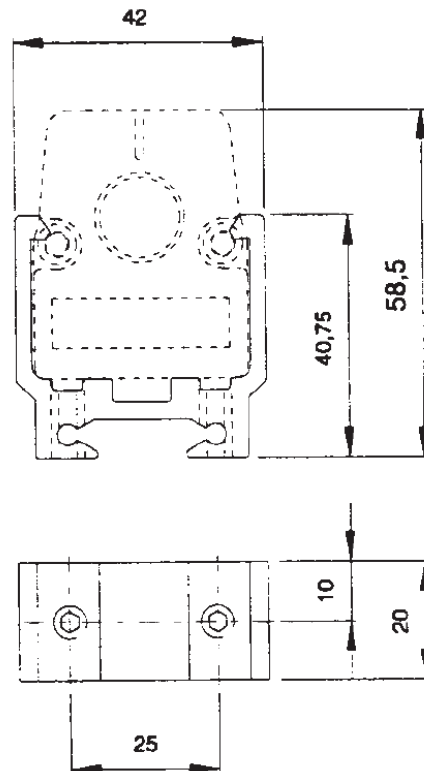

Figure 12

This makes replacement of a unit much easier as the new unit will have the brackets already in the correct position. The position of the clamps on the units is shown in *Figure 13*.

The set screws may not be completely tightened in the supplied position. These set screws *must* be fully tightened before proceeding with the installation. (A 2mm Allen wrench is supplied to allow the brackets to be completely tightened.) If these brackets are not properly secured, the emitter and receiver units may shift causing nuisance tripping, a false lock-out condition and/or a potential safety hazard.

Four wall brackets are supplied with each system together with the 8 self-tapping screws needed to fix the wall brackets to the clamp brackets. The wall bracket dimensions are shown in *Figure 14*.

The alternative mounting arrangements which these brackets facilitate are shown in *Figures 15, 16, & 17*.

The internal construction of the units is such that they can withstand normal levels of vibration and shock. In situations where the vibration of the machine cannot be reduced to normal levels, vibration proofing mountings should be used.

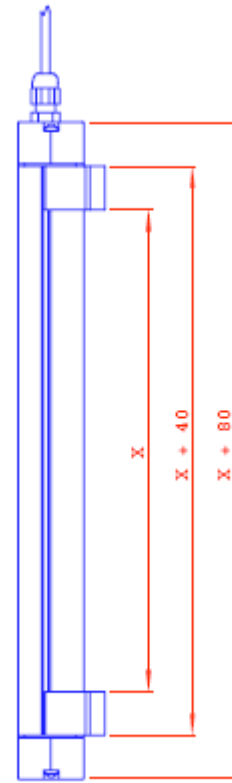

X = Nominal protected height (200, 400, 600, 800 etc.)

Figure 13

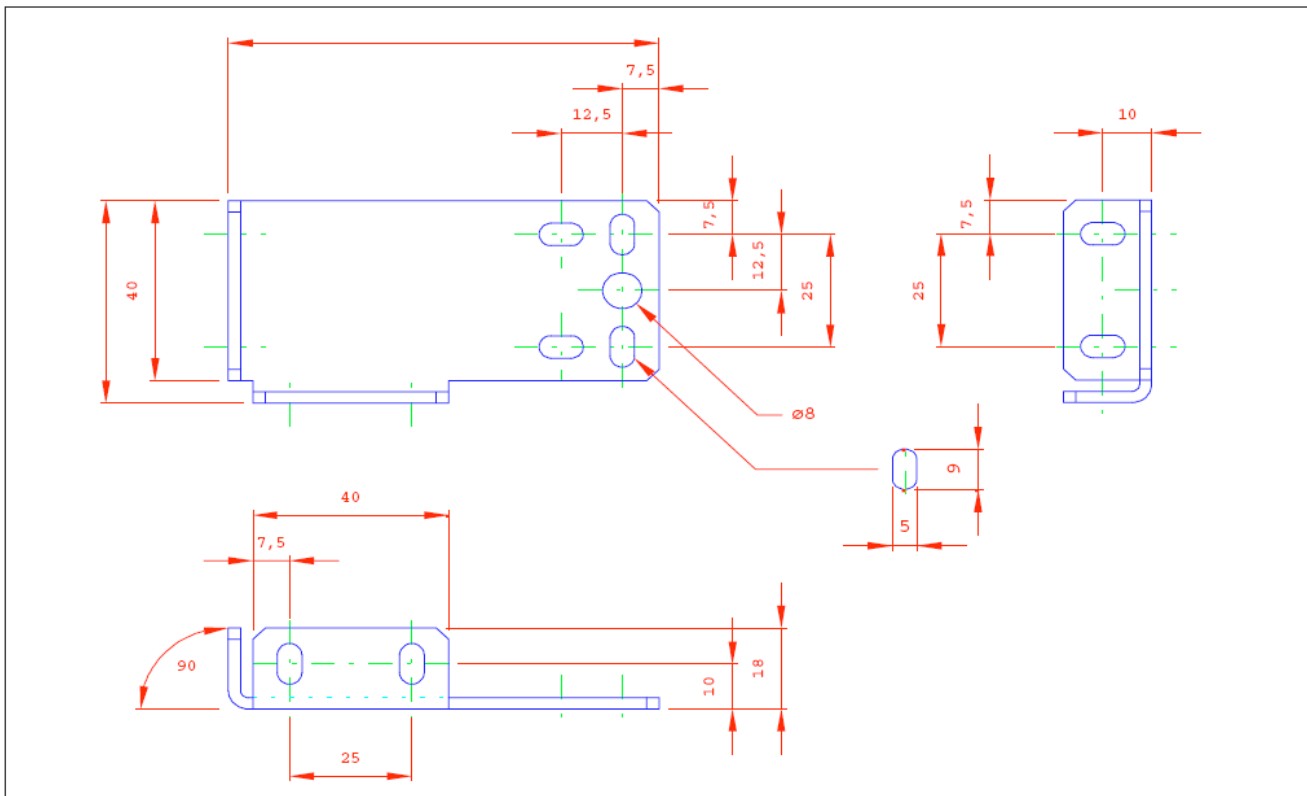

Figure 14

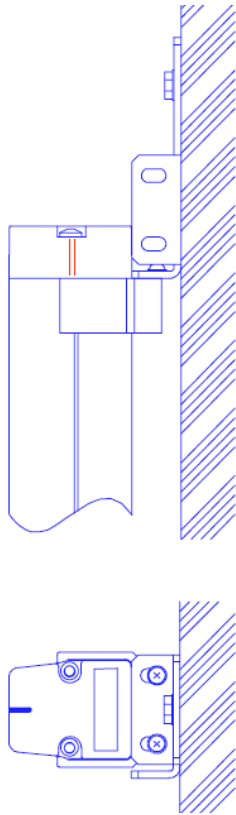

Figure 15

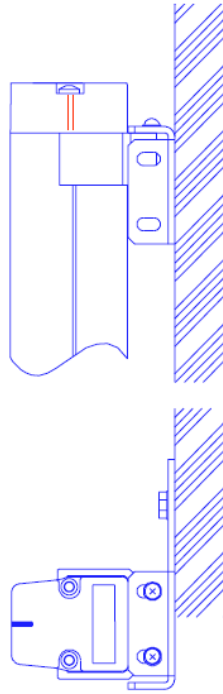

Figure 16

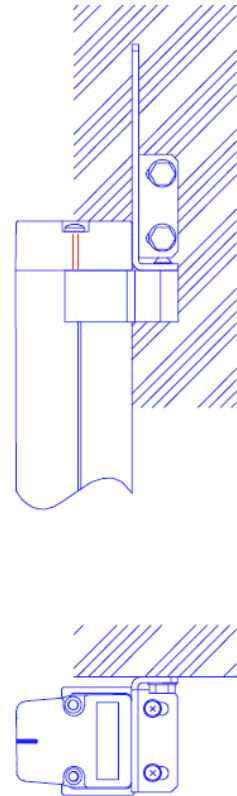
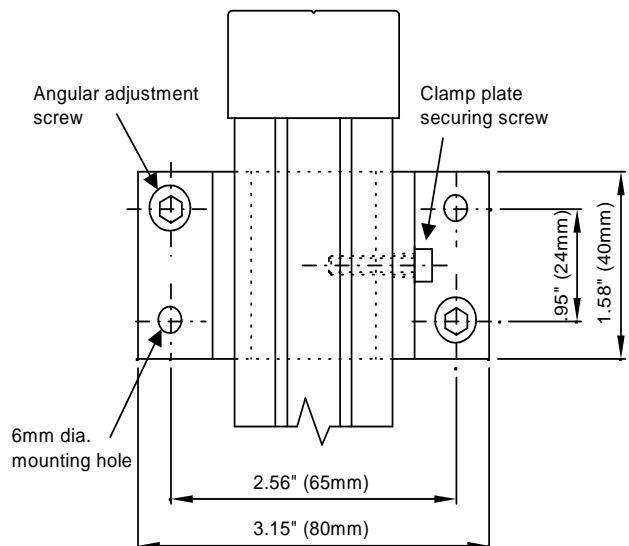
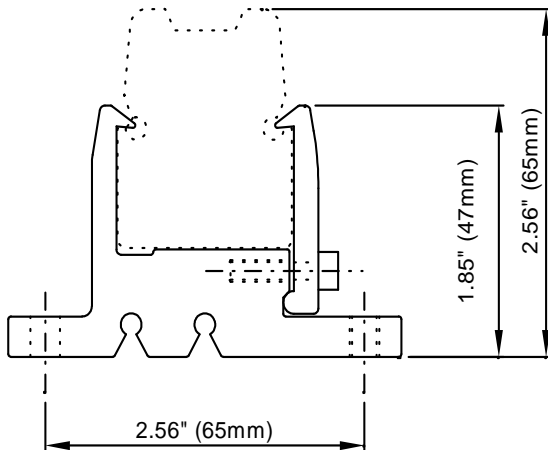

Figure 17

TYPE AB - MOUNTING BRACKETS

Type AB adjustable mounting brackets are an optional choice for B-Series Light Curtains. Combining a robust design and quick release capability, these brackets allow for speedy installation and easy interchange of a light curtain unit without the need for re-alignment. To request this option when ordering your light curtain please specify "AB" in your order code. **(part number 0978)**



3.3 ELECTRICAL INTERFACE, OPERATION, and INSTALLATION

This section is divided into two parts. The first part discusses the interface and operation of the B-Series system when the basic set (emitter and receiver) is interfaced directly to the machine control circuitry by means of the redundant solid state outputs.

The second section discusses the interface when any one of the various Tapeswitch control units is used.

The basic B-Series system consists of an emitter and receiver. The receiver unit provides two safety outputs. These fail-safe outputs are solid-state PNP transistors and are actively monitored and short-circuit protected. The two outputs are independent of each other and represent part of the redundancy of the overall light curtain system. The outputs must always be in the same state (i.e., both outputs either on or off). If one output should fail in the “on” position, the other output will remain in the “off” position until the failure is corrected. In order to maintain redundancy both outputs must be interfaced to independent switching devices in the machine control circuit (i.e., safety relays, emergency stop relay packages, fail-safe PLC'S, etc.). **Both outputs must be used.** The solid state outputs can be interfaced directly to the machine control circuit provided this circuitry is compatible with the PNP-type output. A number of manufacturers produce units containing circuits of this type. Care should be taken to ensure that the inputs of these units can accept the PNP outputs of the light curtain. The B-Series system checks that its outputs are functioning correctly by switching them off for 50 microseconds every 5.5 milliseconds. A dimly lit red LED on the Receiver visually confirms the output checking.

- The maximum current is 0.5A.
- The output voltage, U_a , of each output is dependent on the supply, U_v and the load and is given by the following expression $U_a > U_v - 2v$.
- If the solid state outputs are used directly, the supply voltage to the light curtain (emitter and receiver) must be common to the supply voltage of the device to which it will be interfaced.
- Both outputs must be used to maintain redundancy.
- Each output should be wired to independent switching devices in the machine control circuit and **SHOULD NOT BE CONNECTED TOGETHER.**

NOTE: The pair of solid state outputs are constantly monitored and are designed to act as a single component in a fail-safe condition (i.e., if one of the outputs fails in the “on” position, the other output will revert to the “off” position.

This output will remain “off” until the integrity of the other output is restored. This level of integrity must be maintained throughout the machine control circuit. It is the responsibility of the end user to assure any fault within the safety circuit is detected and that it puts the machine in a safe condition.

3.3.1 GENERAL

Both units must be supplied with 24VDC \pm 20%. This DC supply must be isolated by means of a safety transformer which meets the requirements of IEC60742. The emitter, receiver and interface unit must use the same + 24VDC supply.

The maximum cable length for each unit is 30 meters.

The power consumption is dependant on the protected height of the system but is less than 25VA.

It is recommended that both the emitter and receiver be powered by a common DC supply. If power is removed from the emitter only the system may not re-synchronize, and may require power removal from the receiver as well in order to establish optical communication and synchronization. Power can be removed from the receiver unit without any consequence to the synchronization.

IMPORTANT

Power should be applied to both units at the same time. If power is removed from the emitter unit, power must also be removed from the receiver unit.

3.3.2 EMITTER UNIT

3.3.2.1 General

The emitter unit has a five-pin male quick-disconnect connector. Two pins for the DC supply, two for the test input (see 3.3.2.2), and one for the ground. (protective earth PE)

To connect to the emitter, a 5-pin female molded cable assembly is necessary. This cable assembly is supplied separately and is available in lengths of 15 feet (p/n 0972), 30 feet (p/n 0973), or 98 feet (p/n 0976). This cable has an insulated jacket with color coded wires. The cable has a fixed molded connector on one end and flying leads at the other. The colors and corresponding functions are shown in **Figures 18 and 19.**

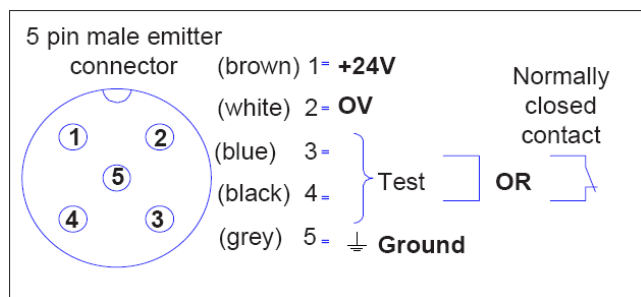

Figure 18

If the test input is not used, this input must be jumpered.

NOTE: If the emitter cable is removed during normal operation, the system will not return to normal operation once the emitter is reconnected until power is cycled on the receiver.

Emitter Unit Cable

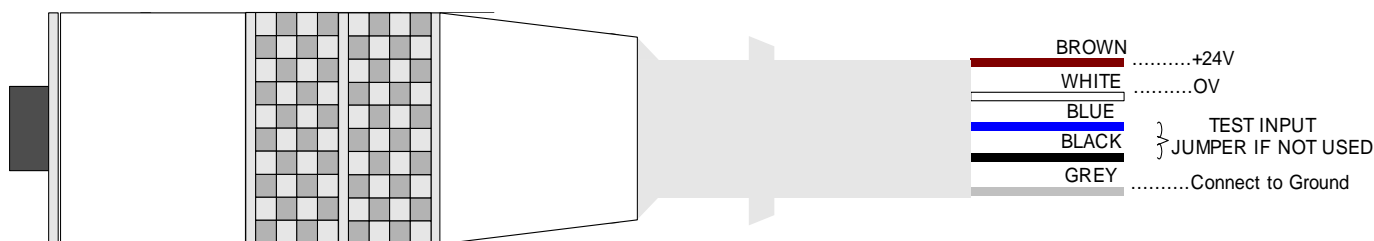

Figure 19

3.3.2.2 Test Input

On some machines, a test input is used to check the interface between the photo-electric safety device and the machine. The input simulates the obstruction of the curtain in order to cycle the output switching elements and thereby expose any fault before the next machine cycle. This input is applied during a safe part of the machine cycle or at the end of the cycle.

If this function is used, a normally closed contact should be connected as shown in **Figures 18 and 19**.

This contact must open for a minimum of 35ms. When this contact is opened, the light curtain safety outputs will be switched off and will remain off until the test contact closes again and the curtain self-tests have been successfully performed (assuming that the curtain is not obstructed).

From re-closing of the test contact, the safety outputs will switch on again after 20ms. The continuous current through the test contact is 7.5mA with in-rush when closing of 30mA.

While the test input is open, a red LED will be visible on the emitter unit and the light curtain outputs (on the receiver) will be in the off state. Once the test input is closed the red LED will be off, and the outputs will be in the on state (provided no faults exist and the light curtain is unobstructed).

3.3.3 RECEIVER UNIT

3.3.3.1 General

The receiver unit has an eight-pin male quick-disconnect connector. Two pins for the DC supply, two for safety outputs (see 3.3.3.3), two for the serial communication interface (see 3.3.3.4) one for ground (protective earth PE), and one for the shield.

The serial communications interface is used for the hand held blanking unit (programming) only. No connections other than the hand held blanking unit (programming) should be connected to the serial communications interface. **These two wires should be left unconnected and isolated from each other to prevent potential shorting.**

To connect to the receiver, an 8-pin female molded cable assembly is necessary. This cable assembly is supplied separately and is available in lengths of 15 feet (p/n 0974), 30 feet (p/n 0975), or 98 feet (p/n 0977). This cable has an insulated jacket with color coded wires. The cable has a fixed molded connector on one end and flying leads at the other. The colors and their corresponding functions are shown in **Figures 20 and 21**.

3.3.3.2 Operation

When power is applied to the receiver, an amber LED should be lit indicating the receiver has +24VDC. If the emitter is powered on, and synchronization has occurred and these units are in alignment then the green LED on the receiver should be lit indicating that the curtain is clear and the outputs are on. **The red curtain-obstructed LED, (adjacent to the green LED) should be dimly lit verifying the outputs are constantly being checked.** When the curtain is obstructed the red LED will fully illuminate and the green LED will be off. The outputs will also be off. A flashing yellow LED on indicates a fault condition has occurred, or the redundant outputs are inadvertently shorted. Under this condition both outputs will be off and the system will require a power cycle once the fault has been corrected (lock-out condition). A steady yellow LED indicates the light curtain system has been programmed for blanking.

3.3.3.3 Safety Outputs

The two output signal switching devices (OSSDs) should be wired to independent switching devices in the machine control circuit. The OSSDs are solid state devices and are actively monitored and short-circuit protected.

The maximum current is 0.5A.

The output voltage, U_A , of each OSSD is dependent on the supply, U_V , and the load and is given by the following expression.

$$U_A > U_V - 2V$$

8-Pin Male Receiver Connector

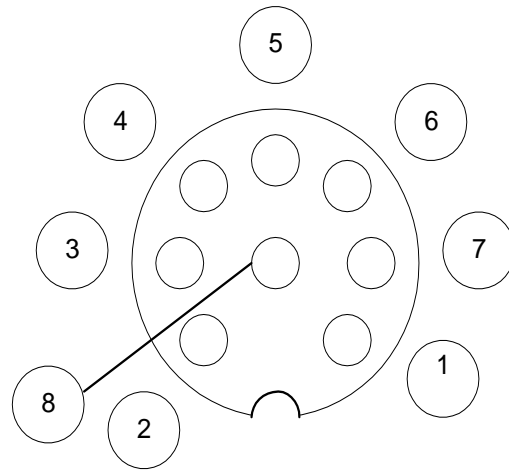
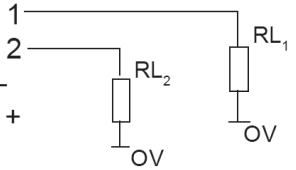

Figure 20

- (WHITE) 1 = 0V
- (BROWN) 2 = +24V
- (GREEN) 3 = \perp Ground
- (YELLOW) 4 = Output 1
- (GREY) 5 = Output 2
- (PINK) 6 - Comm -
- (BLUE) 7 = Comm +
- (SHIELD) 8 = Shield



Receiver Unit Cable



Figure 21

3.3.3.4 Serial Communications

The serial interface is only used for programming the light curtain blanking function. If blanking is not used, these two terminals should be left unconnected.

In order to use the blanking capability of the light curtain, a separate hand-held blanking programming unit, Model BPU-2, is required. It is connected to the receiver unit when setting up the blanking function.

While the BPU-2 unit is connected to the receiver, the outputs from the receiver are disconnected from the machine control circuit or interface unit. Therefore, the machine cannot be operated. Further information regarding blanking the light curtain is contained in the next section of this manual. The hand-held blanking unit is connected in line with the receiver cable as illustrated in **Figure 22** and described below:

Power must be removed from the light curtain prior to connecting and disconnecting the hand held unit.

- Step 1 - Remove the receiver cable (female) from the receiver unit.
- Step 2 - Connect this cable to the male cable on the hand held blanking unit.
- Step 3 - Connect the female cable of the hand held blanking unit to the receiver.

Once the blanking is complete, remove the hand held unit from the system.

NOTE: The system retains the state of the last blanking program, even if power is removed. A STEADILY LIT YELLOW LED ON THE RECEIVER INDICATES THAT THE LIGHT CURTAIN SYSTEM HAS BEEN PROGRAMMED FOR BLANKING.

No equipment other than specified Tapeswitch equipment should be connected to the serial interface terminals.

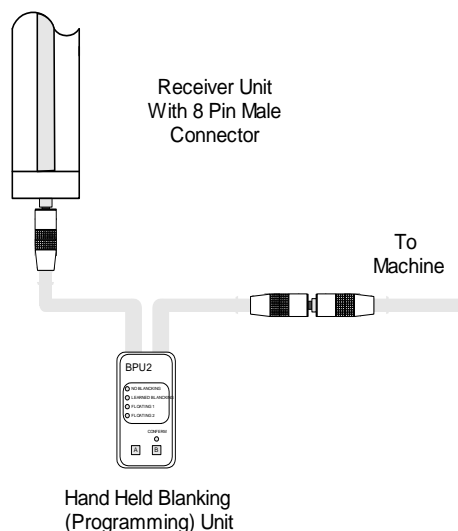

Figure 22

3.4 INITIAL CHECKING AND ALIGNMENT

The procedure for alignment is described below.

Apply power to the B-Series system.

The amber indicators on the emitter and receiver units should be lit. If either of the indicators is not lit, check the wiring.

The green indicator on the receiver unit should be lit, if not, adjust the units into general alignment until the green indicator comes on.

Adjust the units to optimum alignment as follows:

1. Slowly turn the emitter unit clockwise until the green indicator on the receiver unit goes off and the red indicator comes on. (Note this position.)
2. Then turn the emitter unit counter-clockwise, again until the green indicator goes off and the red indicator comes on. (Note this position.)
3. Set the emitter at the center of the two noted positions.
4. Repeat steps 1, 2 and 3 but this time turning the receiver unit.

Using the test piece provided with 14 mm and 30 mm models, obstruct the curtain. On the receiver unit the green indicator should go off and the red indicator comes on.

Move the test piece in and out of the curtain several times and check that the indicators change state appropriately each time.

See section 5.2 of this manual if the system does not function as described above.

The installation of the machine can now be completed. Before putting the machine into use, the complete system (i.e. the machine and all its safeguarding devices) should be commissioned by qualified personnel and, as a minimum, the commissioning checks described in section 5.1.1 of this manual should be performed.

Periodic checks in accordance with section 5.1.2 should be carried out at the prescribed intervals. Daily checks to be performed on the B-Series system are detailed in section 5.1.3 of this manual. In some cases there are specific statutory requirements concerning the examination, inspection and test of a machine and its safety devices. It is for the user to determine if such requirements exist for the machine in question and to ensure that those requirements are met.

4.0 INTERFACE AND AUXILIARY UNITS

4.1 GENERAL

In applications where the two solid state outputs are not suitable for the machine control circuit, an interface unit must be utilized. This interface unit may be user supplied, provided it is compatible with the two solid state PNP outputs and has two channels. A number of manufacturers produce units containing circuits of this type. Care should be taken to ensure that the inputs of these units can accept the PNP outputs of the light curtain. The B-Series system checks that its outputs are functioning correctly by switching them off for 50 microseconds every 5.5 milliseconds. The interface unit must be designed to the same level of integrity as the B-Series in order to maintain the same overall level of safety.

Several Tapeswitch interface units are available which offer options in configuring the input power source, mounting package and type of electrical interface desired. All of the units perform the actual switching of the electrical circuit of the dangerous machine using positively-guided safety relays. All of the ac-powered interface units (BSRSA and BSRUA-2) provide the stepped-down +24VDC power for the B-Series emitter and receiver pair. The dc-powered interface units, (SRUB and SRUS), are powered by an external +24VDC power supply and this supply *must also power the B-Series emitter and receiver pair*. All of the interface units provide isolation from the low amperage B Series solid state outputs (0.5 A each) and the potentially higher amperage required by the machine control circuitry. Each interface unit provides LED status indicators. All LEDs will be discussed in the description of the applicable interface units. These units are described in the appendices of this document.

4.1.1 METHODS OF INTERFACING

All of the interface units have a minimum of two safety outputs. These outputs are to be interfaced with the machine primary control elements (MPCEs). An MPCE is defined as an electrically controlled element which directly controls the normal operating motion of a machine such that it is the last (in time) to operate when motion is initiated or arrested.

The safety output contacts of the interface unit must be connected to a machine's MPCEs in such a way that if either of the safety output relays is switched off, then the machine will be brought to rest, regardless of the state of the other relay.

This gives assurance that the failure of a single relay cannot prevent the machine from being stopped. The safety output relays are cross-monitored within the interface unit. This means any disparity between the two relays will be detected. The machine will be disabled until the cause of the disparity has been removed. Such a disparity could be the loss of signal on one of the two channels coming from the light curtain. The interface will only allow the safety relays to move to the ON state if both channels are working correctly together.

All interface units are provided with indicator lamps which show the status of the interface. The number, color, meaning and location of the indicators may change with the type of interface. All interfaces however, have indicators which specifically show the commanded state of the output safety relays.

Both of these outputs must be used to take advantage of the inherent redundancy of the interface unit.

The two safety outputs are normally (NO). The outputs are closed when no obstructions are in the light curtain and no faults exist. Once the light curtain is broken the outputs open. The state of the output may remain open until a reset switch is applied (**MANUAL RESET**) or will automatically close (**AUTOMATIC RESET**) once the light curtain is cleared. Details of the resetting features are discussed in the individual interface sections found in the appendices.

The safety outputs can be used in several ways, depending on the MPCEs found on the machine being guarded. MPCE is the abbreviation for Machine Primary Control Element. An MPCE is an electrically-powered control device which directly controls the guarded machines motion and is the final device in the operating sequence when motion is either initiated or halted. This would be the main hydraulic control valve in a hydraulically controlled press. Some of the common arrangements are described below:

- Normal risk machine - These usually have a single MPCE. In this case both normally open safety outputs should be used together as shown in **Figure 23**.
- High risk machines - These should have 2 MPCEs. In some countries, it is customary for both MPCEs to operate in the same mode. In this case, each of the normally open (NO) outputs controls a single MPCE. See **Figure 24** for an illustration of the type of interface. Any additional output contacts can be used as a monitor, e.g. as an input to a PLC.

To protect the contacts of the safety output relays from the effects of switching inductive loads, an appropriately rated power factor correction device must be installed across the MPCE coils. **Figures 23 and 24** show Arc Suppressors used for this purpose. Arc Suppressors are user supplied.

CAUTION

Arc Suppressors must not be connected across safety relay contacts.

SAFETY FUSES: It is good practice to protect the safety relays against welding due to a current surge. This can be done by current limiting designs in the machine's controls, or by simple fusing as shown in **Figure 23 and 24**. The current through the safety output contacts should be limited to a level below that which could cause the contact to weld. Fuses with a current rating less than that of the output contacts should be used.

On the BSRSA Interface Unit, these safety (output protection) fuses are part of the unit. All of the other interface units do not provide safety fuses (output protection) and these fuses should be supplied externally by the user.

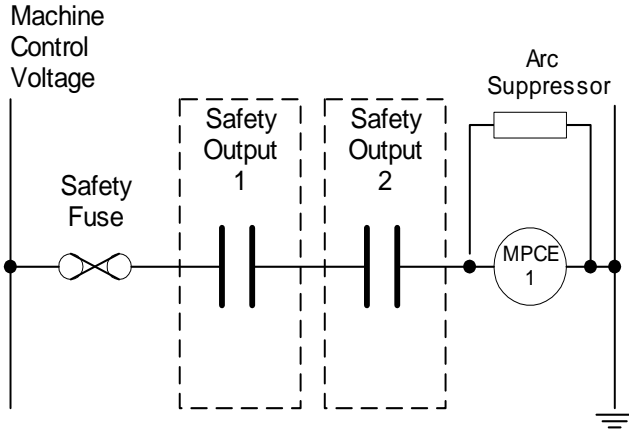

Figure 23 - Interfacing a Machine with 1 MPCE

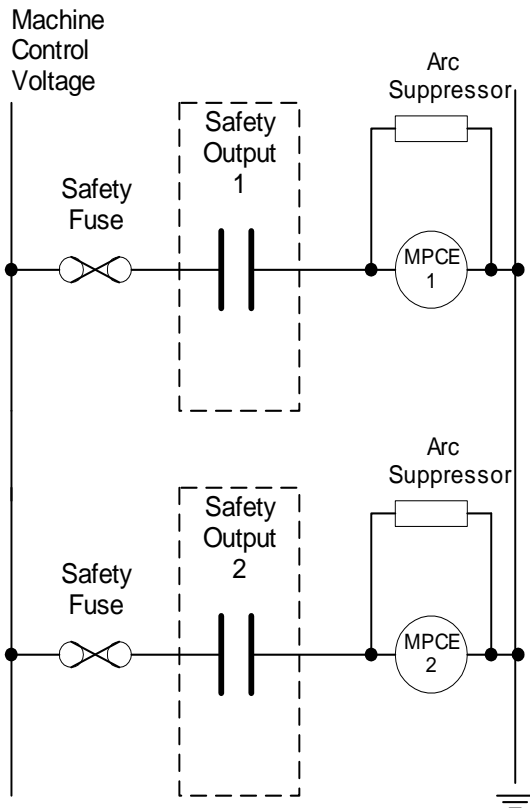

Figure 24 - Interfacing a Machine with Dual Identical MPCEs

5.0 PERIODIC CHECKING, SERVICING, AND MAINTENANCE

5.1 PERIODIC CHECKING

5.1.1 COMMISSIONING CHECKS

The commissioning examination should be carried out by persons who are competent and who possess all the information supplied with the machine and its safety equipment. The results of the examination should be recorded and copies of this record should be kept by the user and the employer of the person performing the examination. The person carrying out the examination should ensure that the following general standard of performance is met:

(a) It should not be possible for the dangerous parts of the machine to be set in motion while the light curtain is penetrated.

(b) Penetration of the light curtain during a dangerous phase of the operation of the machine should result in the dangerous parts being arrested or, where appropriate, assuming an otherwise safe condition, before any part of a person can reach them. It should not be possible for the dangerous parts to be set in motion until the curtain has been cleared, the safety system has been restored to its normal condition, and the machine controls have been reset.

The person performing the examination should also:

(c) Inspect the position of the light curtain to ensure that it is set at the correct distance from the dangerous parts of the machine as recorded on the machine information label or plate.

(d) Ensure that additional safeguarding measures have been provided where necessary to prevent access to the dangerous parts of the machine not protected by the light curtain.

(f) Test the detection capability of the light curtain as described in section 5.1.4 of this manual.

(g) Examine the machine controls and connections to the B-Series system to ensure that the requirements described in this manual and in the machine manual have been met.

(h) Examine the stopping performance monitor (if installed) to ensure that it is installed and functioning correctly. Ensure that the means whereby the stopping performance can be assessed by the operator is indicating correctly.

(i) Test the muting arrangements (if installed).

(j) Examine brakes or clutches (if installed) as recommended.

NOTE: No stopping performance monitor or muting facility is provided with the basic B-Series system and there is no means provided for the connection of such devices to the system. These devices may however have been provided elsewhere in the machine control system.

5.1.2 6 OR 12 MONTH PERIODIC CHECKS

These examinations should be carried out by competent persons. The results should be recorded and a copy kept by the user.

The person should ensure that the general standard of performance as described in section 5.1.1 **(a)** and **(b)** is achieved.

The person should perform the commissioning inspections and tests detailed in section 5.1.1. When checking the stopping performance monitor, item **(h)**, any equally effective means of determining that the overall system response time, as recorded on the machine information label or plate, is not exceeded is acceptable.

In addition the person should:

(a) Examine all switching elements in the switching paths controlled by the light curtain outputs to ensure that they are functioning correctly and are not in need of maintenance and or replacement.

(b) Inspect the machine to ensure that there are no mechanical or structural aspects which could prevent the machine from stopping or assuming an otherwise safe condition when called upon to do so.

(c) Examine and inspect the machine controls and the connections to the B-Series system to ensure that no modifications have been made which could adversely affect that system, and that suitable modifications have been correctly performed and properly recorded.

5.1.3 DAILY/SETTING EXAMINATION

The following tests should be carried out daily by a designated person appointed by the machine user. The results should be recorded and a copy should be kept on or near the machine. Specific statutory requirements may apply to certain types of machines. The designated person should:

(a) Check that access to the dangerous parts of the machine is not possible from any direction not protected by the light curtain and that side and rear guards are in order.

(b) Check that the minimum distance from the dangerous parts of the machinery to the light curtain is not less than the distance stated on the machine information label or plate.

(c) Check that it is not possible for a person to stand between the dangerous parts of the machine and the light curtain.

(d) Check that when the muting facility (if installed) is operative, the moving parts are no longer dangerous.

(e) Check that the stopping performance monitor (if installed) is in use and is set up and functioning correctly.

(f) Check that electrical enclosures are closed and locked and that any keys have been removed for retention by a designated person.

(g) Check for external signs of damage to equipment or to electrical wiring.

(h) Check the detection capability of the B-Series as described in section 5.1.4.

5.1.4 CHECKING DETECTION CAPABILITY

The detection capability of the light curtain should be checked as required in the previous sections using the method described below. See **Figure 25**.

(a) With power applied to the B-Series system and with the machine at rest, check that the light curtain is functioning by observing the state of the appropriate indicators. The green indicator should be on and the red indicator should be off.

(b) Insert the test piece provided with the 14 mm and 30 mm models into the light curtain beams. The axis of the test piece should be perpendicular to the plane of the light curtain. Starting at the top of the emitter unit, position the test piece less than 150 millimeters from the emitter surface, and pass it slowly down the front of the unit. While the full diameter of the test piece is within the area defined by the two arrow markers on the front window, the green indicator should GO OFF AND REMAIN OFF and the red indicator should BE LIT AND REMAIN LIT.

(c) Repeat the above test with the test piece inserted close to the front of the receiver unit and with the test piece inserted at the midpoint between the emitter and receiver units. The indicators should behave as described above whenever the test piece is between the arrow markers.

WARNING

At no time while the test piece is obstructing the curtain should the green indicator come on. If it does the machine must be isolated and must not be used until the cause has been investigated.

(d) If the system passes the above tests proceed as follows. Initiate a cycle of the machine and then insert the test piece into the curtain. Upon insertion of the test piece during dangerous motion, the dangerous parts should come to rest without apparent delay.

WARNING

If the machine does not stop or there is any delay in its response, the machine must be isolated and must not be used until the fault has been rectified.

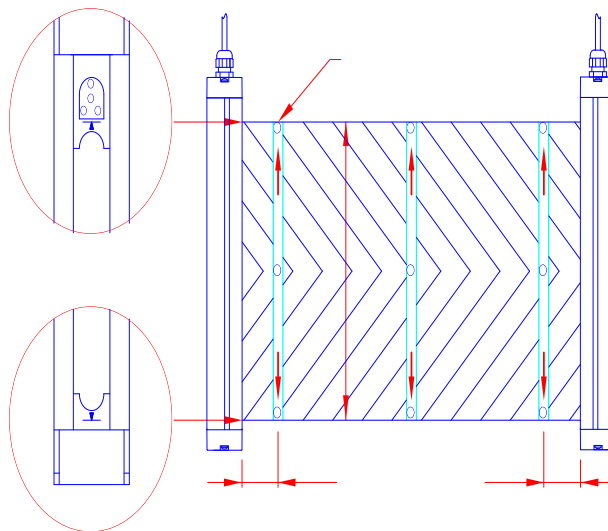

Figure 25 – Light Curtain Detection Test

5.2 SERVICING

The B-Series system is designed to be serviced at unit level. There are no user-serviceable parts within the units.

When a safety-critical fault occurs in the B-Series system or in the machine interface, the machine will be disabled. It is first necessary to establish whether the fault is in the B-Series system or in the machine interface.

Use **Table 2** to identify faults within the B-Series system.

UNIT	STATE OF INDICATORS	CAUSE(S)	ACTIONS(S)
Emitter	Amber LED not lit.	No power to unit	Connect power
	Red LED lit steady	Test input is open	Close test input
	Red LED flashing	Emitter unity faulty	Replace emitter unit
Receiver	Amber LED not lit	No power to unit	Connect power
	Red LED fully lit (no obstruction of curtain)	Units out of alignment	Check alignment
		Test input open on emitter	Check emitter red LED
		Emitter unit faulty	
	No power on emitter unit	Check emitter amber LED	
	Yellow LED flashing	Receiver outputs are shorted	Remove short between outputs
Yellow LED Steady	Light Curtain has been programmed	Reconnect hand held blanking unit and re-configure to correct setting	

Table 2 – Fault Table

NOTE: The emitter and receivers are not matched pairs. They become mated pairs only upon power up. It is not necessary to replace both units, should one become faulty.

5.3 MAINTENANCE

There are no mechanical, electrical or optical adjustments necessary. Apart from occasionally cleaning of the windows on the emitter and receiver units, B-Series systems are maintenance free. Use a soft, lint-free cloth and an anti-static cleaner.

Do not use solvents of any kind.

6.0 TECHNICAL SPECIFICATIONS (Basic B-Series, Emitter and Receiver ONLY)

Protection Height	14mm detection capability		200 to 1200mm
	30mm detection capability		200 to 1800mm
	70mm detection capability		600 to 1800mm
Operating Range	14mm detection capability		6 meters
	30 or 70mm detection capability		13 meters
Detection Capability			14mm, 30mm, 70mm
Effective Aperture Angle			±2°
Response Time for Light Curtain Serial # Ending with A07 and Below			18ms
Response Time For Light Curtain Serial # Ending with D01 and Above	14mm detection	20ms up to 300mm curtain. Additional 4ms for each 100mm of curtain	
	30mm detection	20ms up to 600mm curtain. Additional 4ms for each 200mm of curtain	
	70mm detection	20ms up to 1800mm curtain. Additional 4ms for each 600mm of curtain	
	Multi-Beam	20ms	
Supply Voltage			24VDC ± 20% 5% maximum residual ripple
Power Consumption			<25VA (dependent on protection height)
Enclosure Rating			IP65
Radiation Wavelength	Wavelength		880nm
	Intensity		Class 1 LED product (IEC60825-1)
Safety Output Type	Type		Solid state PNP X 2
	Capacity		0.5A
	Voltage		Supply voltage minus 2V
Type (IEC16496)			4 (self-monitoring)
Operating Temperature			0 - 50°C
Storage Temperature			-20 - 70°C
Humidity			15% to 95% non-condensing
Weight (each unit)			0,3kg plus 0,2kg per 100mm of curtain
Dimensions – Cross Section			36 X 45mm
Minimum Distance			0.50M

APPENDIX A – BSRSA INTERFACE UNIT

1.0 GENERAL DESCRIPTION

The BSRSA interface unit is designed as a stand alone control panel. It interfaces a B-Series light curtain (emitter and receiver) with the guarded machine's controls.

2.0 OPERATIONAL SEQUENCE AND LED STATUS DESCRIPTION

When power is first applied to the light curtain system via the BSRSA:

- A red LED (H3) on the BSRSA controller should illuminate indicating that the control unit has power.
- No power will be supplied to the emitter or receiver of the light curtain and the output status indicators in the BSRSA controller will not be illuminated. All of the outputs will be de-energized and the output contacts will be open, until a reset has been applied.
- Reset the system by the front panel key switch or the external remote reset, if used. See below for details. After the reset switch is released, both the emitter and receiver units of the light curtain should have amber indicators illuminated which shows that power has been applied. If the light curtain is properly aligned, the receiver should have a green LED illuminated which shows the light curtain is clear. If the receiver shows a red LED illuminated, then the light curtain is either not properly aligned, faulty, or obstructed. Once the units are properly aligned and any obstructions are removed, the green LED should be illuminated and the receiver LEDs should follow the state of the light curtain (green indicates curtain clear and red indicates curtain is blocked, obstructed, or misaligned). With the green LED illuminated on the receiver, the output status indicator on the BSRSA controller should be green (H2). The output status indicator on the BSRSA controller will be red (H1) when the curtain is blocked, obstructed, or misaligned.

The redundant safety outputs will follow the state of the light curtain, i.e., if the light curtain is clear; safety outputs 1 & 2 will be closed (energized), but if the light curtain is obstructed, safety outputs 1 & 2 will be open (de-energized)). The safety outputs reset **automatically** the light curtain is cleared again. The safety outputs will not reset (close/energize) if a fault exists.

The lockout contact will close (energize) once the reset sequence has been completed. It will remain closed at all times unless a fault has occurred or power has been removed. The lockout contact does not follow the state of the light curtain. Once the lockout condition occurs

(loss of power or failure) it will be necessary to reset the system.

The monitoring output will follow the state of the safety outputs and should be used for non-safety functions (i.e. indication and status).

- External remote reset can be accomplished by connecting a normally-open, momentary-contact switch to terminal X2 between connections 1 and 2. (This will operate in conjunction with or replace the front panel key reset switch.)

3.0 MECHANICAL INFORMATION

Figure 26 shows the metal enclosure size and mounting dimensions of the BSRSA interface unit. The dimensions are in inches. The BSRSA enclosure is rated for the operating environments found in most manufacturing plants. **Figure 27** shows an internal view of the BSRSA interface unit.

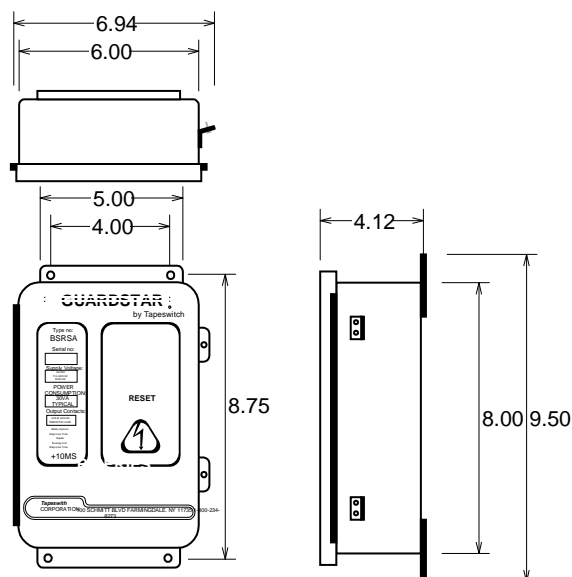

Figure 26 – BSRSA Interface Unit Outline and Dimensions

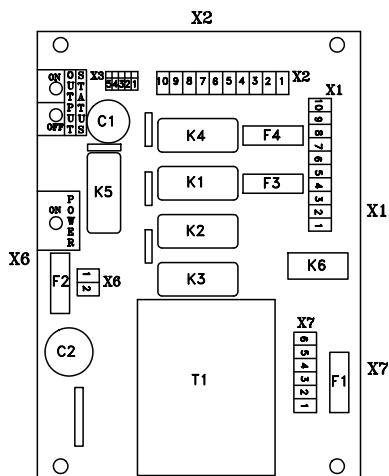

Figure 27 - BSRSA Interface Unit Internal View

4.0 ELECTRICAL CONNECTIONS

The BSRSA interface unit has four internal terminal strips, designated X1, X2, X6, and X7. Each connection point is mechanically suitable for (1) 2.5mm², 14 AWG wire. Crimped ferrules or tinning must be used on all stranded wires. **Figure 28** shows the system block diagram for the BSRSA controller.

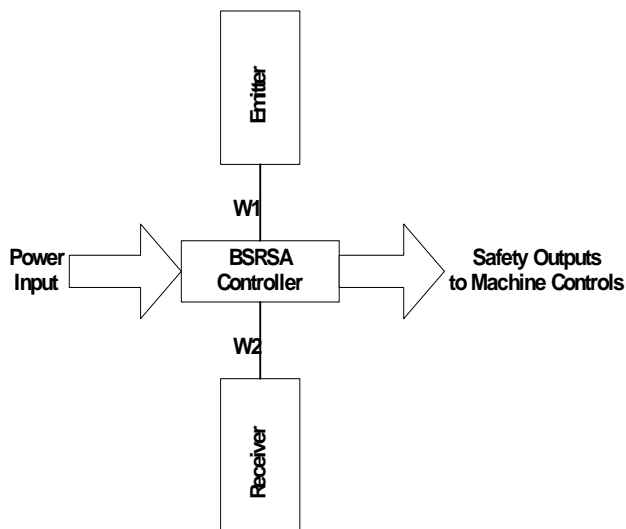

Figure 28 - BSRSA System Block Diagram

Terminal X7 is for AC input power. Terminal X6 is for the +24 Vdc power input. All connections between the BSRSA interface unit and the B-Series light curtain emitter and receiver units are made at terminal X2. All connections between the BSRSA interface unit and the machine's control are made at terminal X1. **Figure 29** show details of the connections for the power, output, and reset functions.

The interconnection diagram (**Figure 30**) and the wire run list (WRL) (**Figure 31**) show the proper terminal numbers and associated functions for the cabling between the B-Series emitter and receiver units and the BSRSA interface unit. Be sure to observe the color coding shown to assure proper operation.

The cables for the interface between the B-Series emitter and receiver units and the BSRSA unit are not included with the light curtain and must be ordered separately. The emitter cable has five conductors in an insulated jacket. The receiver cable has eight conductors in an insulated jacket. The cables have different connectors and will only mate to the proper component of the light curtain.

The metal enclosure has four double knockouts capable of accepting standard 1/2" or 3/4" conduit fittings. It is recommended that any high voltage connection to the BSRSA control unit be made with suitable cabling and/or conduit protections. The connections between the BSRSA and the B-Series emitter and receiver units are non-hazardous, low-voltage signals and additional protection of these cables is not necessary. It is recommended that suitable fittings or cable grips be used to maintain the moisture integrity of the installation. **It is strongly recommended that the low-voltage connections be separated from the high-voltage connections.** Local electrical codes should be observed.

5.0 FUSES

The BSRSA is equipped with four fuses, F1, F2, F3, and F4. See **Figure 27** for the location of these fuses. Fuse F1 is a 500 mA, 250VAC slow-blow type, and is intended to protect from potential shorts and surges on the high voltage side of the interface unit. Fuse F2 is a 1.2 A, 250VAC quick-blow type and is intended to protect from potential shorts in the low voltage, 24VDC, circuitry of the interface unit. Fuses F3 and F4 are output protection fuses. These fuses are 3.15A, 250VAC slow-blow types, and protect the safety output relay contacts from welding due to current surges or excess loading. Care should be taken to replace any fuses with the correct rating. While replacing any fuses, particular attention should be given to the fuse holder. Excess stress on the fuse holders during replacement can lead to intermittent connections, which may cause nuisance tripping and/or a nuisance lock-out condition.

6.0 TEST INPUT

The BSRSA interface includes a test input. This input is used to check the interface between the photo-electric safety system and the machine. It electrically simulates an obstruction in the light curtain. While in the normal or run mode, the test input is jumpered (closed). It is opened and closed when used for testing. The machine's control logic can verify that the safety output relays did, in fact, cycle, thereby exposing any fault before the next machine cycle.

This test should be conducted during a safe part of the machine cycle, or at the end of the cycle. While the test input is opened, power is removed from the light curtain (both emitter and receiver). Once the test input is closed, power is restored to the light curtain. The emitter and receiver may take a few seconds to re-synchronize, and, consequently, the safety outputs may take a few seconds to resume their normal state. The device connected to the test input should have a dry contact which is closed during the run mode and momentarily opened during the test mode.

The test input is located on terminal X1, connections 9 and 10. If the test input is not utilized, a jumper should be installed across these connections. (This feature is seldom used and, therefore, a removable jumper is installed at the factory.)

7.0 MONITOR/AUXILLIARY OUTPUT

A non-safety monitor/auxiliary output is also provided. This is a solid state relay output which is closed when the light curtain is clear and is open when the light curtain is obstructed, a fault exists, or a lockout condition is present. This output is provided on terminal X1, locations 1 and 2. This output can be used for display and status indication purposes. It must not be used for safety-related machine control and switching functions.

8.0 TECHNICAL SPECIFICATIONS

Specifications		Data	Tolerance
Supply Voltages		110 VAC 240 VAC	+ 10% - 15%
		24 VDC	+ 10% - 15%
Safety Outputs	Type	Positively guided, forced contact	
	Contacts	Two (NO) for use with FSDS (Final Switching Devices) One (NO) for lockout use, (Secondary Switching Device)	
	Rating	4.0 A resistive load @ 240VAC 4.0 A resistive load @ 24VDC 5 Hz maximum rate	
	Fusing	Two (2), 3.15Amp, internal	
Monitor/Auxiliary Output		0.5 Amp, 48 VDC 10 Watt max	
Dimensions		9.50 in. (241mm) high 7.00 in. (178mm) wide 4.12 in. (105mm) deep	
Weight		Approximately 7 lbs.	
Enclosure Rating		NEMA TYPE 1 (standard) NEMA TYPE 12 (available)	
Connecting Terminals	Type	Captive terminals, with removable headers	
	Capacity	One 2.5mm sq. (AWG 14)	



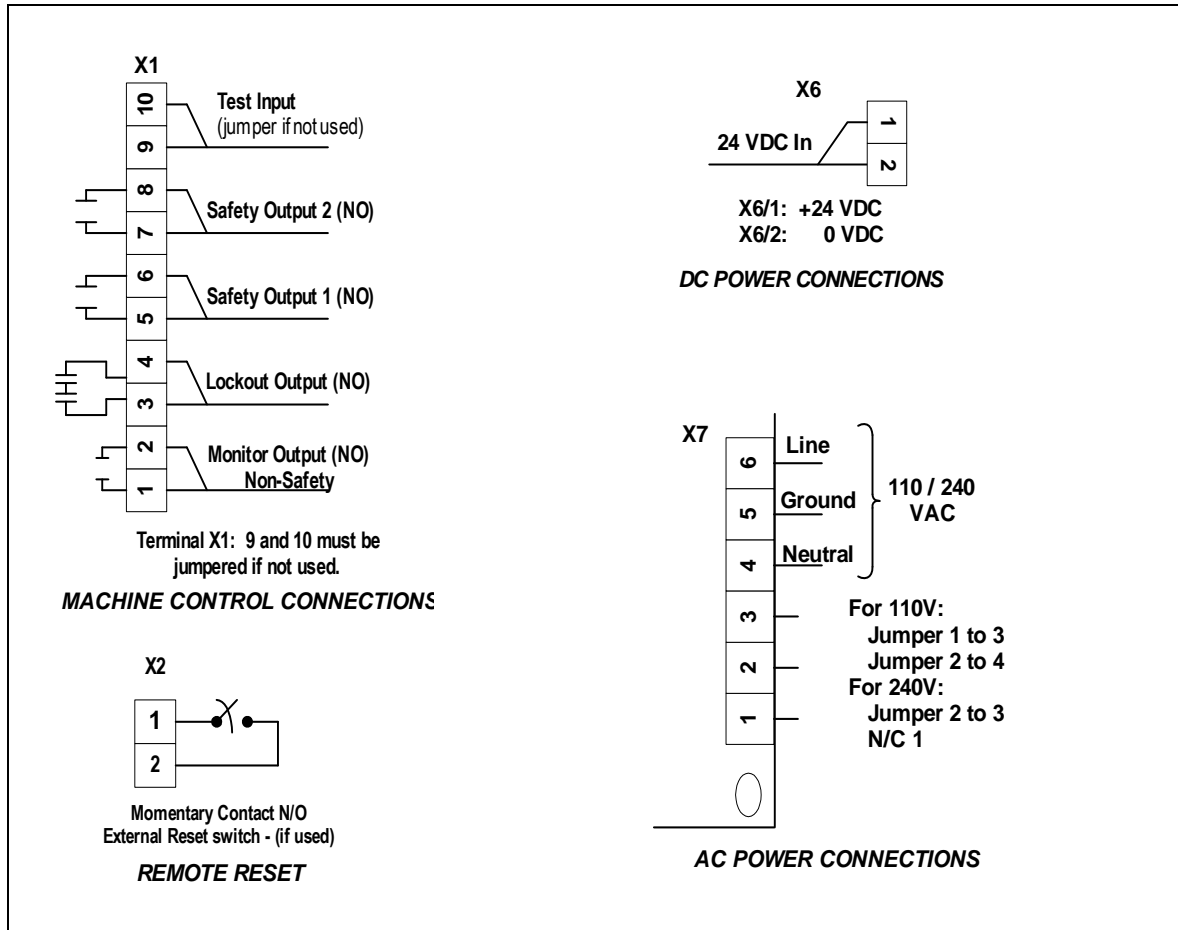

Figure 29 - BSRSA Terminal Numbers and Functions

NOTE: Connection from the emitter and receiver is made to terminal X2, see Figure 30 for details.

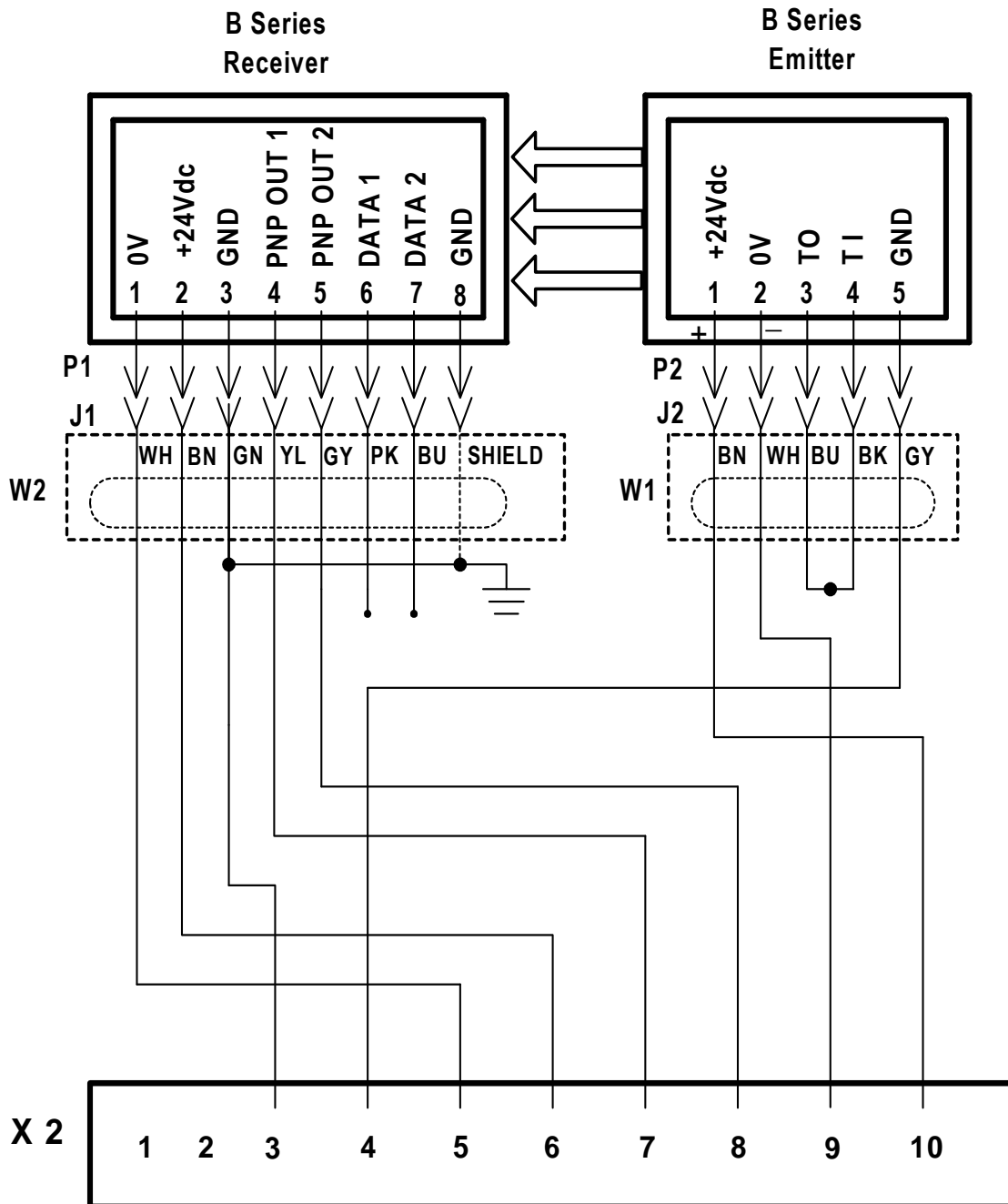

Figure 30 –Light Curtain to BSRSA Interconnection Diagram

Cable #	Cable Type	Color Code	Function	From	To
	RKT5-612/XX			Emitter 5 Pin Quick Disconnect	BSRSA Terminal X2
W1	"	Brown	+24VDC	1	10
W1	"	White	OV DC	2	9
W1	"	Blue	Test Out	3} Jumper 3 to 4, if not used	No Connection
W1	"	Black	Test In	4} Jumper 4 to 3, if not used	No Connection
W1	"	Gray	Ground	5	4
	RKT8-09/XX			Receiver 8 Pin Quick Disconnect	BSRSA Terminal X2
W2	"	White	OV DC	1	5
W2	"	Brown	24VDC	2	6
W2	"	Green	Ground	3	3
W2	"	Yellow	Output 1	4	7
W2	"	Gray	Output 2	5	8
W2	"	Pink	Data (-)	6} Isolate 6 & 7	No Connection
W2	"	Blue	Data (+)	7} Isolate 6 & 7	No Connection
W2	"	Shield	Ground	8	Ground

Figure 31 – Wire Run List for BSRSA

APPENDIX B – BSRUA-2 INTERFACE UNIT

1.0 GENERAL DESCRIPTION

The BSRUA-2 interface unit is designed to be incorporated into the user's machine control system. It interfaces either one or two B-Series light curtains with the protected machine's controls.

2.0 OPERATIONAL SEQUENCE AND LED STATUS DESCRIPTION

2.1 CONFIGURED FOR ONE LIGHT CURTAIN

When power is first applied to the light curtain system:

- Two amber LEDs on the BSRUA-2 Controller should illuminate, indicating that the control unit has power (system status LEDs for channel 1 & channel 2).

- Power is automatically applied to the emitter and receiver units and, if the system is properly connected and aligned (see the following wiring information), and the light curtain is clear with no faults, the BSRUA-2 controller should have two green LEDs illuminated. These LEDs indicate that the output status (for channel 1 and channel 2) is "on" and the redundant output safety relays are in the "on" state or closed. The outputs will remain closed until an obstruction or fault occurs in the light curtain. When the light curtain is obstructed, both red LEDs will illuminate and flash. These LEDs indicate that the output status (channel 1 and channel 2) is "off" and the redundant output safety relays are in the "off" state or opened.

The outputs will remain opened until the light curtain is clear. The outputs follow the state of the light curtain and reset AUTOMATICALLY without any operator intervention. It is important to note the BSRUA-2 controller does not distinguish between a light curtain fault, obstruction, misalignment, or wiring error. All of these conditions cause the BSRUA-2 to respond as if the light curtain is obstructed and the redundant safety outputs will be in the "off" state (opened).

2.2 CONFIGURED FOR TWO LIGHT CURTAINS

When power is first applied to the light curtain system:

- Two amber LEDs on the BSRUA-2 Controller should illuminate indicating that the control unit has power (system status LEDs for channel 1 and channel 2).

- Power is automatically applied to the emitters and receivers on both light curtains, and, if the system is

properly connected and aligned (see the following wiring information), and the light curtains are clear with no faults, the BSRUA-2 Controller should have two green LEDs illuminated. These LEDs indicate the output status (for channel 1 and channel 2) is "on" and the redundant output safety relays are in the "on" state or closed. The outputs will remain closed until an obstruction or fault occurs in either of the two light curtains. When a light curtain is obstructed, the corresponding red LED will illuminate and flash. These LEDs indicate the output status (both redundant safety outputs are "off"), and also identify which light curtain (emitter 1/receiver 1 or emitter 2/receiver 2) has been obstructed. Channel 1 flashing red indicates that light curtain one has been obstructed, and channel 2 flashing red indicates that light curtain two has been obstructed. For the light curtain which is unobstructed, the green output status LED will remain steadily lit.

It is important to note that although a green LED status indicator may be illuminated, the redundant safety outputs may actually be off as a result of the other light curtain being obstructed. The LEDs are designed to assist the user determine which light curtain has caused the output to go to the off state.

The outputs will remain opened until both light curtains are clear. The outputs follow the states of the light curtains and reset AUTOMATICALLY without any operator intervention. It is important to note the BSRUA-2 does not distinguish between a light curtain fault, obstruction, misalignment, or wiring error. All of these conditions cause the BSRUA-2 to respond as if a light curtain is obstructed, and the redundant safety outputs will be in the "off" state (opened).

3.0 MECHANICAL INFORMATION

Figure 32 shows the case size and mounting dimensions of the BSRUA-2 interface unit. All dimensions are in millimeters. The unit must be mounted in an enclosure rated for the known operating environment. In most cases, the unit will fit into an existing machine's control unit panel. The unit snaps onto a common electrical mounting rail, style DIN EN 50 022-35.

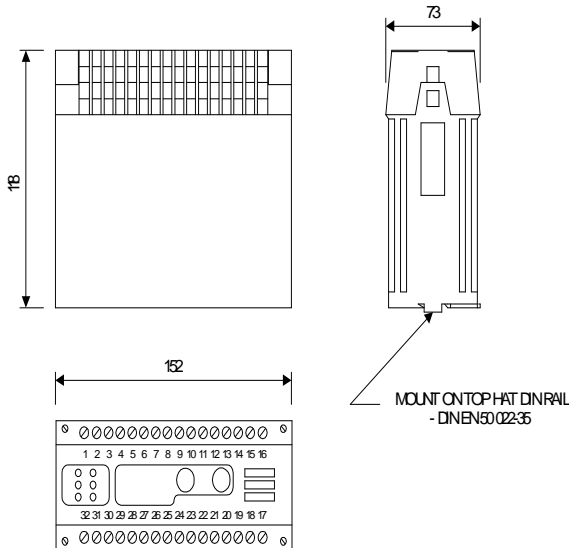

Figure 32 - BSRUA-2 Interface Unit Outline & Dimensions

4.0 ELECTRICAL CONNECTIONS

Figure 32 also shows the 32 integral connection terminals, in two rows along the top of the interface unit. The terminals are numbered 1 to 32. Each terminal is suitable for up to two (2) 2.5mm² (14 AWG) solid wires. Crimped ferrules or tinning must be used on all stranded wires.

Figures 33 and 34 show system block diagrams for the BSRUA-2 Controller. Figure 33 shows the configuration for one light curtain. Figure 34 shows the configuration for two light curtains. Figure 35 shows the terminal numbers for the input and output functions (Input Power, ac/dc, and the redundant safety outputs). These functions and terminal numbers are the same for either the one or two light curtain configuration. The necessary jumpers for the different configurations are noted. They must be installed properly in order to insure the correct and safe operation of the system. Some jumpers may be factory installed, and the user must insure that the unit is configured properly for the intended use.

All connections between the BSRUA-2 and the light curtain(s) must be made with the proper emitter and receiver cables (ordered separately).

For the case where one light curtain is used, refer to Figures 36 and 37. These show the interconnection diagram and the wire run list (WRL) and give the proper terminal numbers and their associated functions for the cabling between the B- Series emitter and receiver units and the BSRU-2A controller.

For the case where two light curtains are used, refer to Figures 38 and 39. These show the interconnection diagram and the wire run list (WRL) and give the proper terminal numbers and their associated functions for the cabling between the B- Series emitter and receiver units and the BSRU-2A controller.

Be sure to observe the color coding shown to assure proper operation.

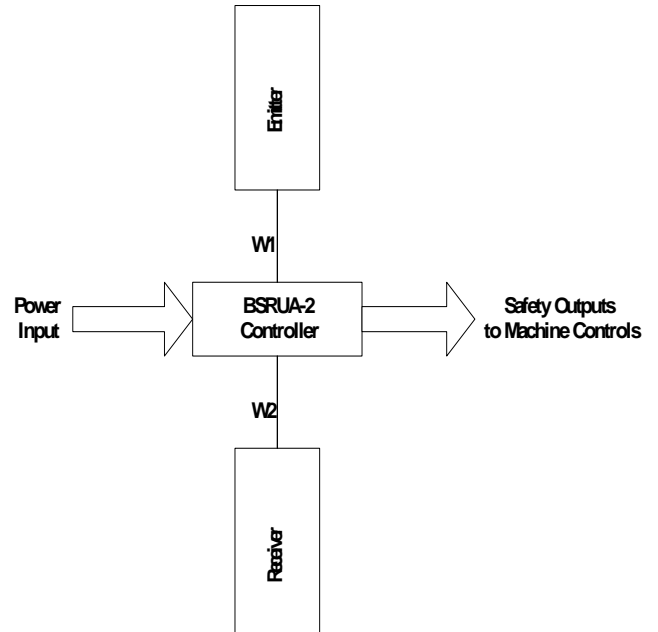

Figure 33 – System Block Diagram for the BSRUA-2 Interface Unit Configured for ONE Light Curtain
(See Figures 36 and 37 for detailed connections)

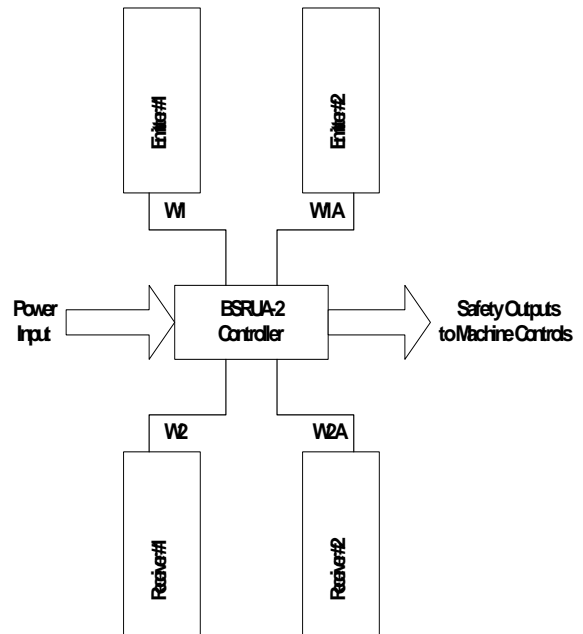

Figure 34 - System Block Diagram

**for the BSRUA-2 Interface Unit
Configured for TWO Light Curtains**

(See Figures 38 and 39 for detailed connections)

5.0 FUSES

The BSRUA-2 is equipped with two fuses, F1 and F2. Both fuses are located on the top of the Din Rail enclosure. These fuses are secured with a spring-loaded twist mechanism. They are easily accessed with a common flathead screw driver. Fuse F1 is a 1 amp, 250VAC, quick-blow type, and is intended to protect from potential shorts and surges on the high-voltage side of the interface unit. Fuse F2 is a 2 amp, 250VAC quick-blow type, and is intended to protect from shorts and surges in the low-voltage, 24VDC circuitry of the interface unit. It is recommended that external fuses be used to prevent the safety output contacts from welding (as described in section 4.1.1 of the main document).

6.0 TEST INPUT

The BSRUA-2 interface provides a test input for each light curtain. This input is used to check the interface between the photo-electric safety system and the machine. It electrically simulates an obstruction in the corresponding light curtain. While in the normal or run mode, the test input is jumpered (closed). It is opened and closed when used for testing. The machine's control logic can verify that the safety output relays did, in fact, cycle, thereby exposing any fault before the next machine cycle.

This test should be conducted during a safe part of the machine cycle, or at the end of the cycle. While this input is open, power is removed from the corresponding light curtain (both emitter and receiver). Once the test input is closed, power is restored. The emitter and receiver may take a few seconds to re-synchronize, and, consequently, the safety outputs may take a few seconds to resume their normal state. The device connected to the test input should have a dry contact which is closed during the run mode and momentarily opened during the test mode.

The test inputs are located at terminals 7 and 8 for light curtain number one and terminals 19 and 20 for light curtain number two. The test input on terminals 19 and 20 is active for the TWO light curtain configuration ONLY. This input will have no effect in the single light curtain configuration. If these inputs are not used, jumpers should be installed on these terminals. (This feature is seldom used and, therefore, removable jumpers are installed at the factory).

7.0 TECHNICAL SPECIFICATIONS

Specifications		Data	Tolerance
Supply Voltages		110 VAC 240 VAC	+ 10% - 15%
		24 VDC	+ 10% - 15%
Safety Outputs	Type	Positively guided, forced contact	
	Contacts	Two normally open (NO)	
	Rating	4.0 A resistive load @ 240VAC 4.0 A resistive load @ 24VDC 5 Hz maximum rate	
	Fusing	3.0 A recommended, by user	
Dimensions		6.00 in. (152mm) long, 2.88 in. (73mm) wide, 4.65 in. (118mm) high	
Weight		Approximately 2 lbs.	
Enclosure Rating		IP 20	
Enclosure Mounting		DIN EN 50 022-35	
Connecting Terminals	Type	Captive terminals	
	Capacity	Two 2.5mm sq. (AWG 14)	



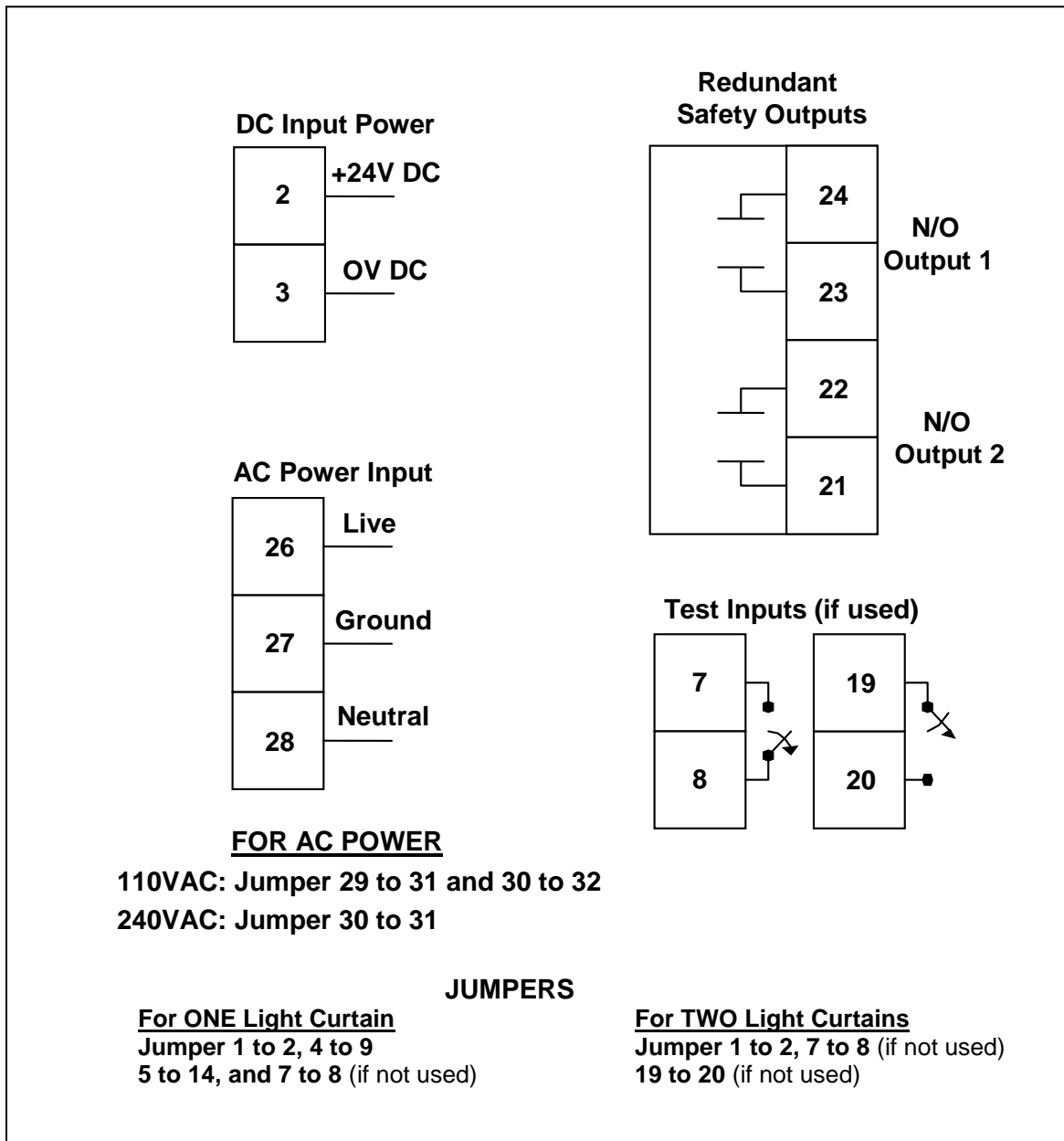

Figure 35 - Input and Output Functions, Jumper Details and Terminal Numbers for the BSRUA-2

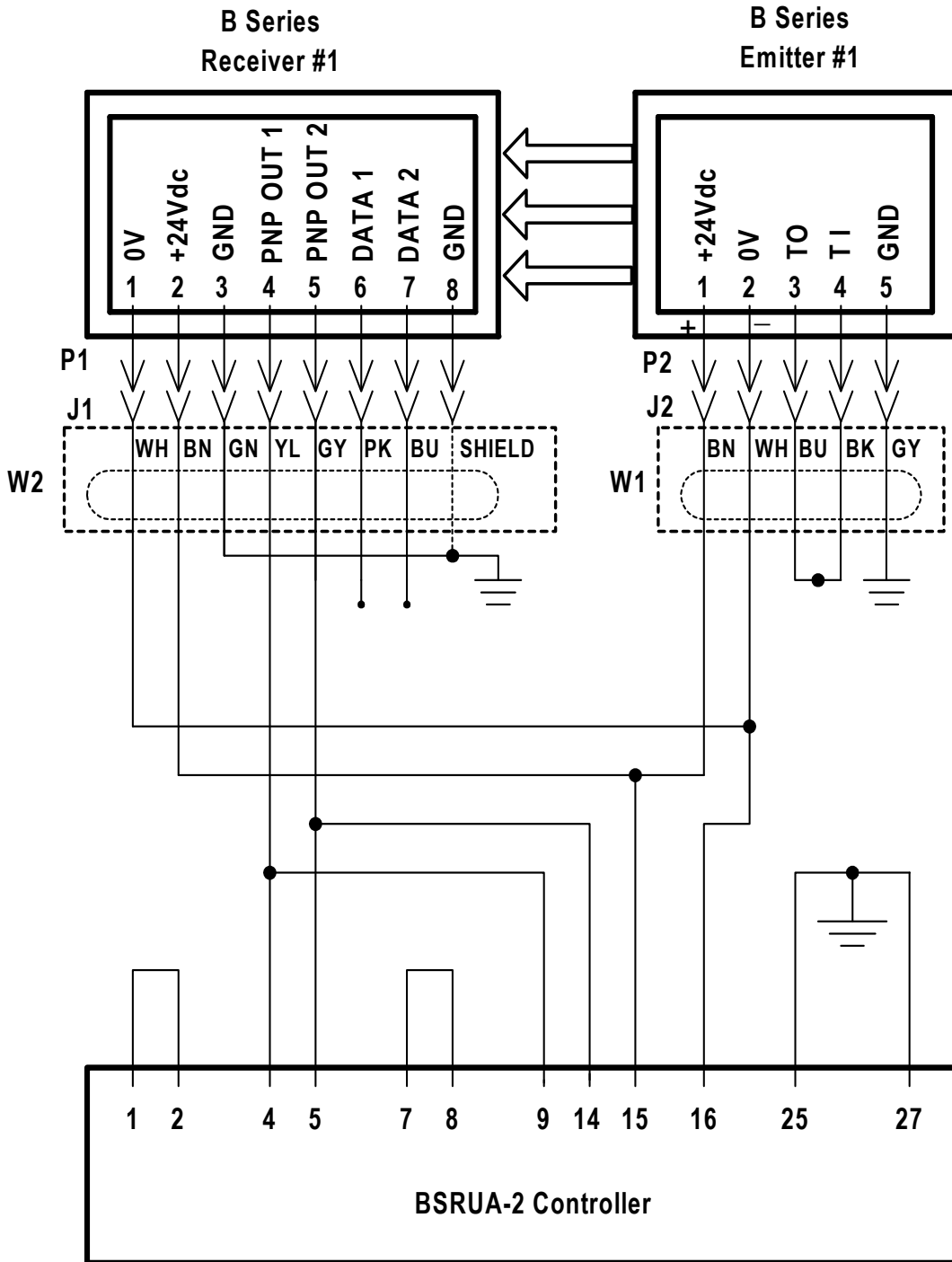

Figure 36 – Interconnection Diagram for the BSRUA-2 ONE Light Curtain Configuration

CABLE #	CABLE TYPE	COLOR CODE	FUNCTION	FROM	TO
	RKT5-612/XX			Emitter 5 Pin Quick Disconnect	BSRUA-2
W1	"	Brown	+24V D.C.	1	15*
W1	"	White	OV D.C.	2	16*
W1	"	Blue	Test Out	3} Jumper 3 to 4, if not used	No Connection
W1	"	Black	Test In	4} Jumper 4 to 3, if not used	No Connection
W1	"	Gray	Ground	5	25, 27, or Ground
	RKT8-09/XX			Receiver 8 Pin Quick Disconnect	BSRUA-2
W2	"	White	OV D.C.	1	16*
W2	"	Brown	24V D.C.	2	15*
W2	"	Green	Ground	3	25, 27, or Ground
W2	"	Yellow	Output 1	4	4
W2	"	Gray	Output 2	5	5
W2	"	Pink	Data (-)	6} Isolate 6 & 7	No Connection
W2	"	Blue	Data (+)	7} Isolate 6 & 7	No Connection
W2	"	Shield	Ground	8	Ground

* Denotes Double Connection

Figure 37 – Wire Run List for the BSRUA-2 ONE Light Curtain Configuration

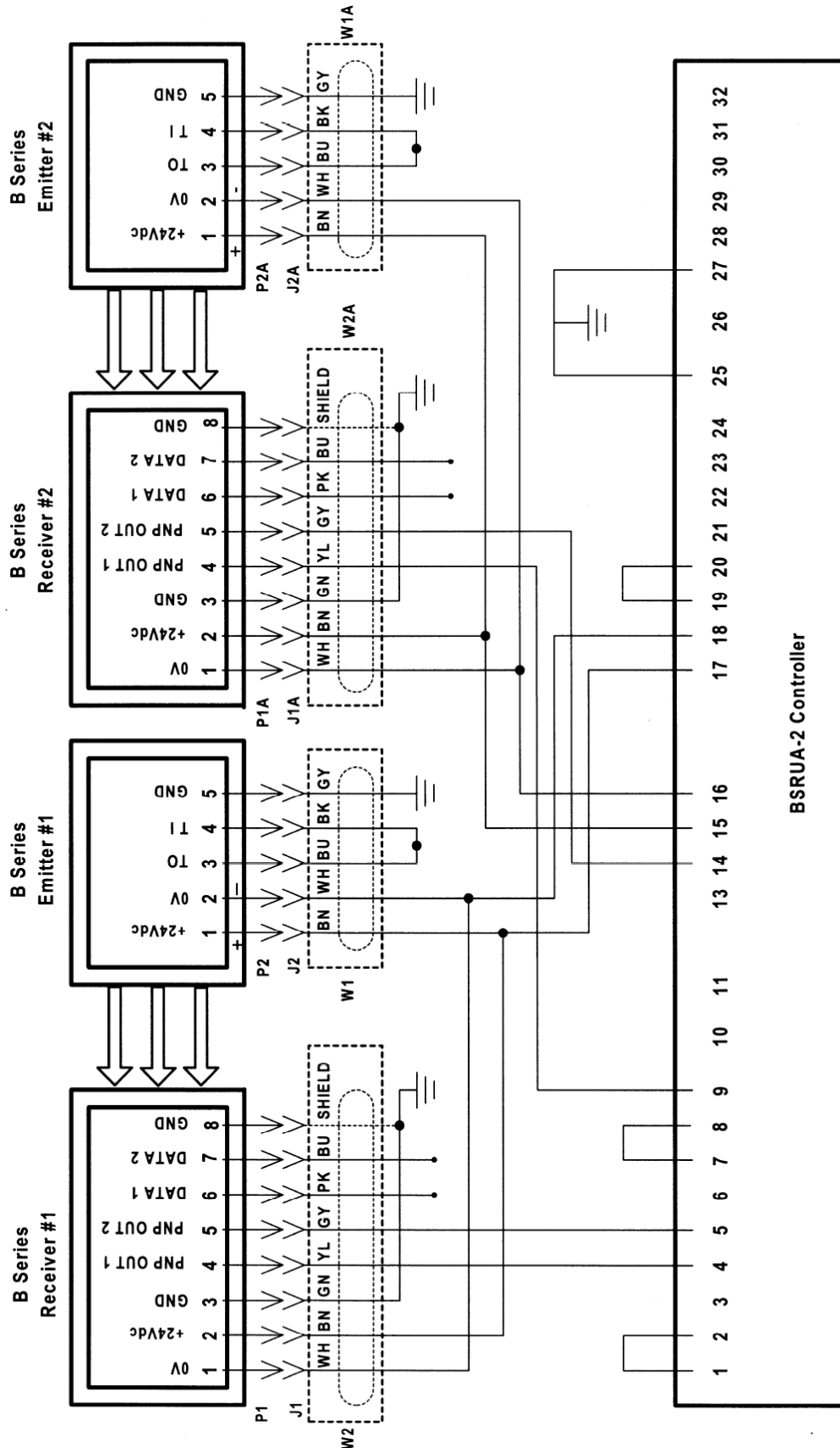

Figure 38 – Interconnection Diagram for the BSRUA-2 TWO Light Curtain Configuration

CABLE #	CABLE TYPE	COLOR CODE	FUNCTION	FROM	TO
	RKT5-612/XX			Emitter #1 5 Pin Quick Disconnect	BSRUA-2
W1	"	Brown	+24V D.C.	1	17*
W1	"	White	OV D.C.	2	18*
W1	"	Blue	Test Out	TWIST PAIR TOGETHER Black and Blue Wire	No Connection
W1	"	Black	Test In		No Connection
W1	"	Gray	Ground	5	25, 27, or Ground
	RKT5-612/XX			Emitter #2 5 Pin Quick Disconnect	BSRUA-2
W1A	"	Brown	+24V D.C.	1	15*
W1A	"	White	OV D.C.	2	16*
W1A	"	Blue	Test Out	TWIST PAIR TOGETHER Black and Blue Wire	No Connection
W1A	"	Black	Test In		No Connection
W1A	"	Gray	Ground	5	25, 27, or Ground
	RKT8-09/XX			Receiver #1 8 Pin Quick Disconnect	BSRUA-2
W2	"	White	OV D.C.	1	18*
W2	"	Brown	24V D.C.	2	17*
W2	"	Green	Ground	3	25, 27, or Ground
W2	"	Yellow	Output 1	4	4
W2	"	Gray	Output 2	5	5
W2	"	Pink	Data (-)	6} Isolate 6 & 7	No Connection
W2	"	Blue	Data (+)	7} Isolate 6 & 7	No Connection
W2	"	Shield	Ground	8	25, 27, or Ground
	RKT8-09/XX			Receiver #2 8 Pin Quick Disconnect	BSRUA-2
W2A	"	White	OV D.C.	1	16*
W2A	"	Brown	24V D.C.	2	15*
W2A	"	Green	Ground	3	25, 27, or Ground
W2A	"	Yellow	Output 1	4	9
W2A	"	Gray	Output 2	5	14
W2A	"	Pink	Data (-)	6} Isolate 6 & 7	No Connection
W2A	"	Blue	Data (+)	7} Isolate 6 & 7	No Connection
W2A	"	Shield	Ground	8	25, 27, or Ground

* Denotes Double Connection

Figure 39 – Wire Run List for the BSRUA-2 TWO Light Curtain Configuration

APPENDIX C – SRUB INTERFACE UNIT

1.0 GENERAL DESCRIPTION

The SRUB interface unit is designed to be incorporated into the user's machine control system. It interfaces a B-Series light curtain with the protected machine's controls. The SRUB requires a +24VDC input, which must be common with the +24VDC supplied to the light curtain.

2.0 OPERATIONAL SEQUENCE AND LED STATUS DESCRIPTION

Note: The LEDs on the SRUB provide status indication of the output state of the safety relays only. No status indicators for the light curtain (emitter and receiver) are provided on this unit.

2.1 RESETTING OPTIONS

The SRUB interface can be configured for either a manual (latched) reset or an automatic reset. In the manual reset mode, the safety outputs will go to the "off" state (opened) once the light curtain is obstructed and *remain* in the "off" state until the obstruction is removed **and** an external (user supplied) reset switch is activated. Once this reset sequence is completed, the safety outputs will resume the "on" state (closed). In the automatic reset mode, the safety outputs will follow the state of the light curtain (i.e., light curtain clear: outputs "on" (closed), light curtain obstructed: outputs "off" (opened). The operational sequence for both reset options is described below.

2.1.1 Manual Reset

When power is first applied to a light curtain system in manual reset mode:

- No LEDs will be illuminated until a manual (external) reset is applied.
- Once the external reset is applied, the two green LEDs (channel 1 and channel 2) will illuminate. (Provided the system is properly wired, no faults exist and the B-Series emitter and receiver units have power and are properly aligned.) This indicates that both safety relay outputs are in the "on" or closed state. Both LEDs must be illuminated in order for the guarded machine to operate.
- These outputs will remain "on" (closed) until the light curtain is obstructed, faulty or misaligned. If an obstruction occurs, both green LEDs will go off and remain off. The LEDs will remain off, even if the light curtain is cleared, until a reset is applied.

- Once a reset is applied the two LEDs will illuminate, and the safety output relays will return to the "on" (closed) state.

2.1.2 Automatic Reset

When power is first applied to a light curtain system in automatic reset mode:

- Both green LEDs will illuminate and the safety output relays will be "on" (closed). The LEDs and outputs will remain on, provided the light curtain is clear.
- When the light curtain is obstructed, both LEDs will go off and the safety outputs contacts will also go to the "off" (open) state. They will remain off until the light curtain is clear.
- Once the obstruction is removed, both LEDs will illuminate and both safety output relays will return to the "on" state.
- If one of the output signals from the B-Series light curtain is disconnected, the corresponding LED (channel 1 or channel 2) will go off. Both safety output relays will also go off and remain off. The system will not reset, even if the signal is restored. This condition is considered a catastrophic failure and requires a power-down/power-up cycle to restore normal operation (provided this failure has been rectified).

3.0 MECHANICAL INFORMATION

Figure 39 shows the case size and mounting dimensions of the SRUB interface unit. All dimensions are in millimeters. The unit must be mounted in an enclosure rated for the known operating environment. In most cases, the unit will fit into an existing machine's control unit panel. The unit snaps into a common electrical mounting rail, style DIN EN 50 022-35.

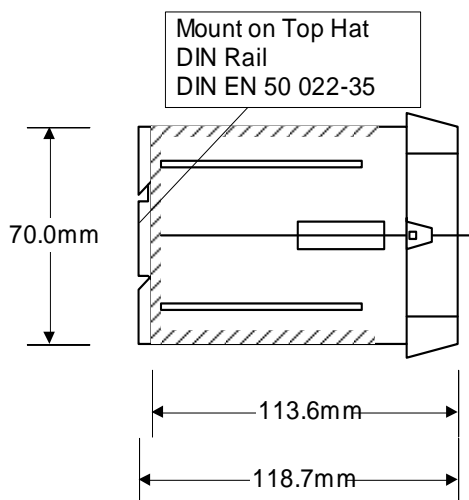
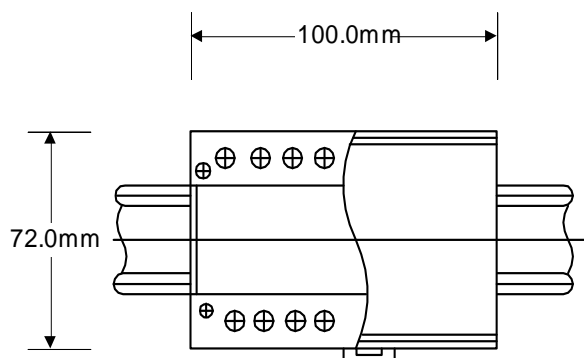

Figure 39 - SRUB Interface Unit Outline & Dimensions

4.0 ELECTRICAL CONNECTIONS

The SRUB controller has twenty integral connection terminals, in two rows, along the top of the unit. The terminals are marked according to their intended function. Each terminal is suitable for up to two (2) 2.5mm² (14 AWG) solid wires. Crimped ferrules or tinning must be used on all stranded wires. **Figure 41** shows the system block diagram for the SRUB controller. **Figure 42** shows the terminal numbers for the various input and output functions.

Particular attention should be given to the jumper placements for configuring MANUAL RESET and AUTOMATIC RESET. These jumpers must be installed properly in order to insure the correct and safe operation of the system.

Note: Improper installation of the jumpers may lead to false indication of the two green LEDs (channel 1 and channel 2). For example, both LEDs may be illuminated, indicating both safety outputs are “on” (closed), however, the outputs may actually be “off” (opened) without the proper jumper configuration.

Figures 43 and 44 show the interconnection diagram and the wire run list (WRL) and give the proper terminal numbers and their associated functions for the cabling between the B- Series emitter and receiver units and the SRUB controller. All connections between the SRUB and the light curtain (emitter and receiver) must be made with the proper emitter and receiver cables (order separately).

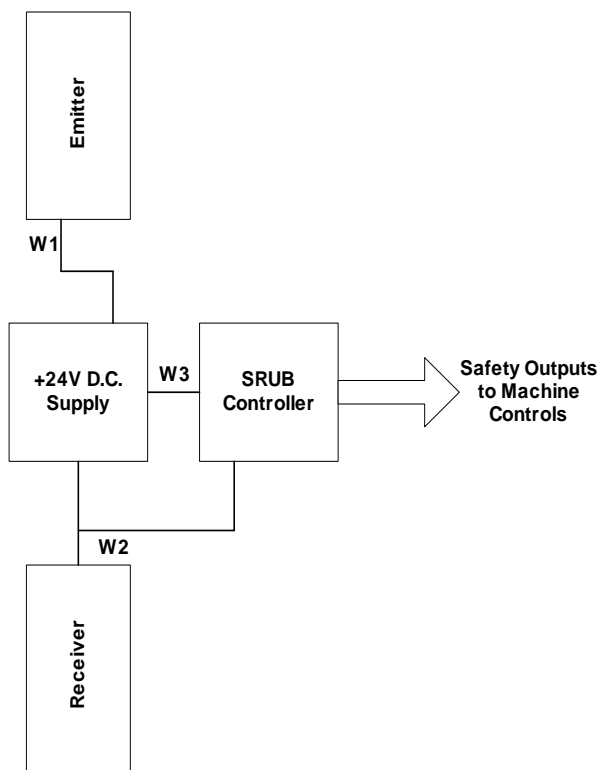

Figure 41 System Block Diagram For the SRUB Interface Unit

4.1 MONITOR INPUT (Manual Reset Mode ONLY)

The SRUB interface unit provides a machine monitor input. This monitor input receives a closed contact from the machine's control circuit. Under normal conditions this input will be closed at all times. If a fault occurs external to the light curtain system, the machine's control circuit must provide an open to this input. This open contact must remain open until the external fault is rectified. If the fault persists (input remains open) and the light curtain system is cycled while obstructed, the SRUB unit will not reset. Under this condition, all of the LEDs will be off. The system will be capable of resetting only *after* this monitor input is closed (machine/external fault corrected). If this feature is not used, the most common case, a jumper must be installed between X1 and X2 (**when in the manual reset mode**).

4.2 EXTERNAL RESET (Manual Reset Mode ONLY)

In the manual reset mode, the SRUB Controller requires an external reset switch. This switch should be a normally-open, momentary-contact type. The location of the reset switch must be such that any person resetting the safety system must be able to completely see the hazardous area. The system should not be able to be reset if an operator is within the hazardous area, or if a fault exists in the safety system and/or machine control circuitry. The reset circuit of the SRUB Controller is designed to protect against a failure (failed closed) or by-pass of the reset button. The reset circuit requires a closure and return to an open position. Replacing the reset switch with a simple jumper will not convert the SRUB Controller to automatic reset operation. (For automatic reset operation, see the jumper configuration in **Figure 42**.)

4.3 MONITOR/AUXILIARY OUTPUT

A non-safety monitor/auxiliary output is also provided. This output is a normally-closed relay contact which is open when both safety outputs are closed (light curtain clear) and closed when both safety outputs are open (light curtain obstructed). This output can be used for display and status indication purposes. It must not be used for safety-related machine control and switching functions.

5.0 FUSES

The SRUB interface unit contains no user-accessible fuses. It is recommended that the +24VDC supply voltage be self-regulated and protected against any possible faults or surges from the SRUB controller. It is also recommended that external fuses be used to prevent the safety output contacts from welding (as described in section 4.1.1 of the main document).

6.0 TECHNICAL SPECIFICATIONS (SRUB)

Operating voltage	24 VDC at +/- 10%
Power consumption	approximately 5 VA
Contact configuration	2 N/O safety contact, 1 N/C auxiliary contact
Contact type	Relay positive guided
Operating temperature	-25°C to +50°C
Terminal/Housing style	DIN 40050 (Terminal IP20) (Housing IP40)
Conductor connection	2 x 2.5mm ² solid wire DIN 26206 or 1 x 1.5mm ² stranded wire with ferrule DIN 46228
Max switching capacity	1500 VA
Switching voltage	250 VAC, 24 VDC Resistive load
Switching current	6A AC, 6A DC

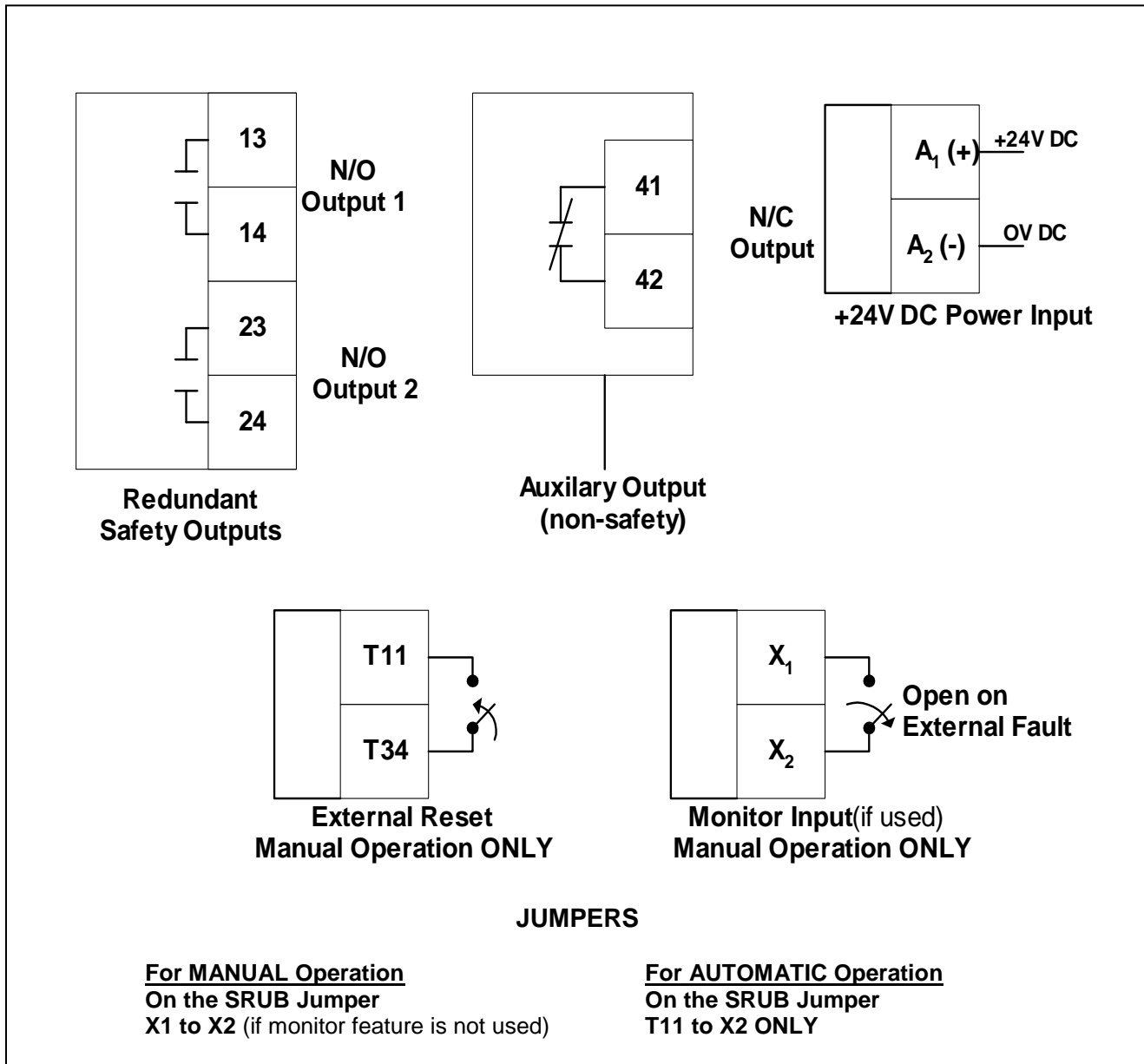

Figure 42 Input and Output Functions, Jumper Details and Terminal Markings for the SRUB

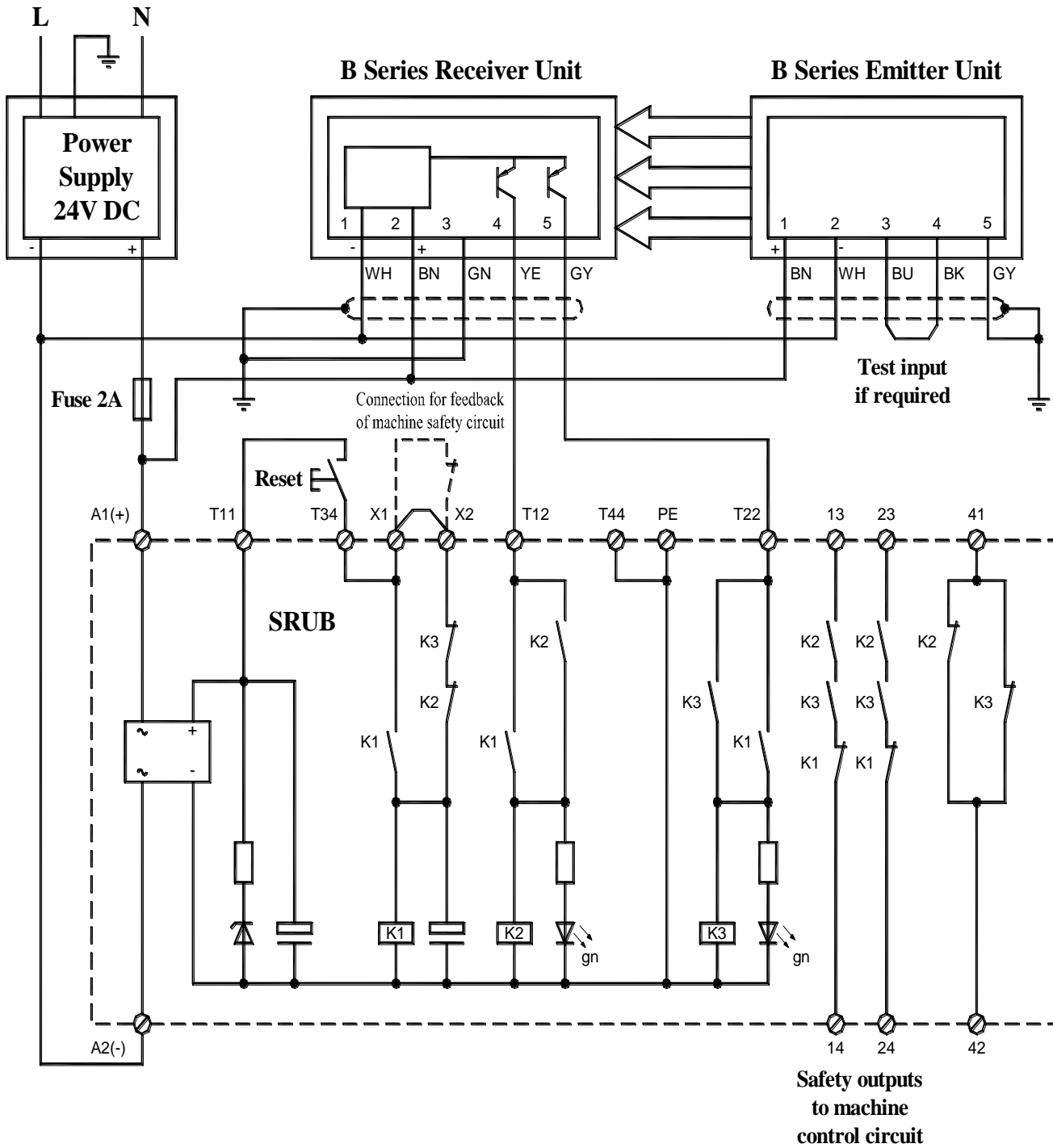

Figure 43 – Light Curtain to SRUB Interconnection Diagram

CABLE #	CABLE TYPE	COLOR CODE	FUNCTION	FROM	TO
	RKT5-612/XX			Emitter 5 Pin Quick Disconnect Molded/Pre-wired	+24V DC Power Supply
W1	"	Brown	+24V DC	1	+24V DC
W1	"	White	OV DC	2	OV DC
W1	"	Blue	Test Out	3	TWIST PAIR TOGETHER Black & Blue Wire
W1	"	Black	Test In	4	
W1	"	Gray	Ground	5	Ground
	RKT8-09/XX			Receiver 8 Pin Quick Disconnect Molded/Pre-wired	Split Cable +24V DC Power Supply
W2	"	White	OV DC	1	OV DC
W2	"	Brown	+24V DC	2	+24V DC
W2	"	Green	Ground	3	Ground
				Receiver 8 Pin Quick Disconnect Molded/Pre-wired	SRUB
W2	"	Yellow	Output 1	4	T12
W2	"	Gray	Output 2	5	T22
W2	"	Pink	Data (-)	6	No Connection Isolate 6 & 7
W2	"	Blue	Date (+0)	7	
W2	"	Shield	Ground	8	PE
	User Supplied	User Defined		24V DC Power Supply	SRUB
W3	"	"	+24V DC	-	A1 (+)
W3	"	"	OV DC	-	A2 (-)
W3	"	"	Ground	-	PE

Figure 44 – Wire Run List for the SRUB Interface Unit

APPENDIX D – SRUS INTERFACE UNIT

1.0 INTRODUCTION

Tapeswitch SRUS interface control units are designed to be used with B-Series Light curtains to form a complete safety system. Full system installation instructions are supplied with the light curtains.

2.0 PRODUCT DESCRIPTION

The SRUS interface unit operates from 24Vdc supply. The unit is housed in a DIN rail mounting enclosure with 16 integral terminals. This unit is intended to be mounted in an existing electrical enclosure on the machine. This existing enclosure must be sealed to minimum rating of IP54.

3.0 PRINCIPLE OF OPERATION

When power is first applied, relays K1 & K2 are de-energized and there is no path through the safety contacts 13-14 and 23-24. When the reset switch is closed (Y1 - Y2) there will still be no path through the safety contacts. When the reset switch is opened again the path through the safety contacts is established.

If the light curtain is then obstructed, its outputs go off and the safety contacts open. Even when the light curtain is clear again the safety outputs remain open until the reset is repeated.

The unit provides both a manual or auto reset function.

In manual reset mode, the reset function provides start and restart interlock functions as follows:

START INTERLOCK - When power is applied to the system, the output relays cannot be energized until a reset signal has been applied.

RESTART INTERLOCK - Once the light curtain has been obstructed and the output relays have de-energized, they cannot be energized again until the light curtain has been cleared and a reset signal has been applied.

The start/restart interlock function must be incorporated somewhere in the machine safety system. However, this function may be provided by equipment other than the light curtain, i.e., it may already be included in the machine control circuit. In such a case, the light curtain interface should function in an auto-reset mode.

In auto-reset mode the output relays will be energized whenever power is applied to the system and the light curtain is clear, and the output relays will re-energize immediately after an interruption is cleared.

In manual or auto reset mode, reset will be prevented while the light curtain is obstructed, if there is a fault in the reset circuit or if the two output relays are in disparity.

The safety output contacts of the control unit are connected to the machine primary control element(s) in such a way that if either of the safety output relays is de-energized then the machine will be brought to rest regardless of the state of the other relay.

NOTE: A machine primary control element or MPCE is defined as 'an electrically controlled element which directly controls the normal operating motion of a machine such that it is the last (in time) to operate when motion is initiated or arrested'.

In addition, where the machine control system has two MPCEs, these devices can be monitored by connecting normally closed auxiliary contacts from each MPCE in series with the reset input. Disparity between the two MPCEs will prevent a reset.

4.0 INSTALLATION

WARNING

TAPESWITCH SAFETY SYSTEMS ARE DESIGNED TO PROTECT OPERATORS WORKING AT OR NEAR DANGEROUS MACHINES. THEY CAN ONLY PERFORM THAT FUNCTION IF THEY ARE CORRECTLY FITTED AND INTERFACED TO A SUITABLE MACHINE. EVERY EFFORT HAS BEEN MADE TO PROVIDE COMPREHENSIVE AND ACCURATE INFORMATION. IT IS THE RESPONSIBILITY OF THE USER TO ENSURE THAT ALL PERSONS INVOLVED IN THE INSTALLATION OF THE PRODUCT HAVE THE KNOWLEDGE, TRAINING AND EXPERIENCE NECESSARY AND THAT THEY ARE FULLY CONVERSANT WITH ALL LAWS, RULES, REGULATIONS AND CODES OF PRACTICE PERTAINING TO THEIR TASK.

4.1 MECHANICAL

4.1.1 GENERAL

The SRUS interface unit should be mounted in the machine control unit on standard 'top hat' terminal rail type DIN EN 50 022-35. The machine control unit must provide sealing to IP54 according to IEC 529. The dimensions of the SRUS interface unit are shown in **Figure 45**.

Mechanical vibrations greater than 5g / 33Hz should be avoided when in transportation and when in operation.

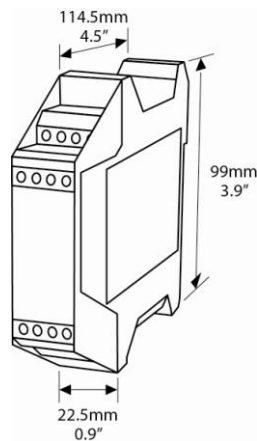

Figure 45 – Dimensions

4.1.2 RESET INPUT DEVICE

A normally open switch, preferably a 22mm industrial pushbutton, should be used to provide the reset input. The switch should be housed in a suitable enclosure and should be mounted in such a position that it is safe from passing traffic and such that the person operating the switch can see all of the dangerous area.

4.2 ELECTRICAL

4.2.1 GENERAL

The connections for the SRUS interface unit are shown in **Figure 48**. Crimped ferrules should be fitted on all stranded wires. The exact cabling requirements are at the discretion of the installer and depend to a large extent on the siting of the various control system elements. In general, it is recommended that high voltage cables are routed away from low voltage cables.

4.2.2 LIGHT CURTAIN CONNECTION

Connect the fail-safe PNP inputs from the B-Series light curtain terminals 4 & 5 (cable colors yellow & grey) to terminals S12 & S22, as shown in **Figure 48**.

4.2.3 POWER CONNECTION

Connect +24VDC to terminal A1 (+) & connect 0V to terminal A2 (-) as shown in **Figure 48**. The power consumption is approximately 2.5VA.

4.2.4 RESET INPUT CONNECTION

If the machine has two MPCEs, a pair of normally closed auxiliary contacts from each MPCE can be connected in series as follows: For manual reset connect across terminals Y1 & Y2 see **Figure 46**. For Auto Reset connect across terminals Y1 & Y2 see **Figure 47**. This provides cross-monitoring of the MPCEs such that if they are in disparity due to a fault, reset will be prevented until the fault is rectified.

If there is no external monitoring, fit a link across the terminals.

4.2.5 SAFETY OUTPUT CONNECTION

Two normally open safety outputs are provided. In low to medium risk applications the machine is normally provided with a single MPCE. In such cases both safety outputs should be connected in series with the MPCE coil as shown in **Figure 49**. If the machine is fitted with two MPCEs one safety output should be connected in series with each MPCE coil as shown in **Figure 50**.

To protect the contacts of the safety output relays from the effects of switching inductive loads, it is recommended that arc suppressors should be fitted in parallel with the MPCE coils as shown **Figures 49 and 50**. Arc suppressors must not be fitted across the safety relay contacts.

To protect against the possibility of both safety outputs welding in, due to an overcurrent fault in the machine circuit, 6A quick blow, or 4A slow blow fuses should be fitted in series with the MPCE coils as shown in **Figures 49 and 50**. This limits the current through the safety output contacts to well below that which could cause the contacts to weld.

4.2.6 MONITOR OUTPUT

If auxiliary signal contacts are required, the normally open contacts across terminals 33 & 34 can be used.

NOTE: All outputs of the SRUS are safety outputs and can be used in the machine stop circuit.

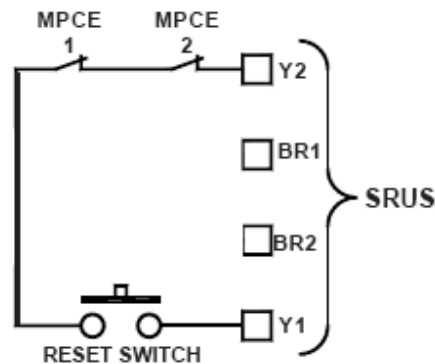

Figure 46- Cross-monitoring of MPCEs - Manual Reset

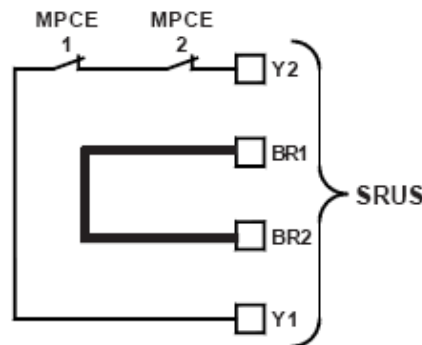
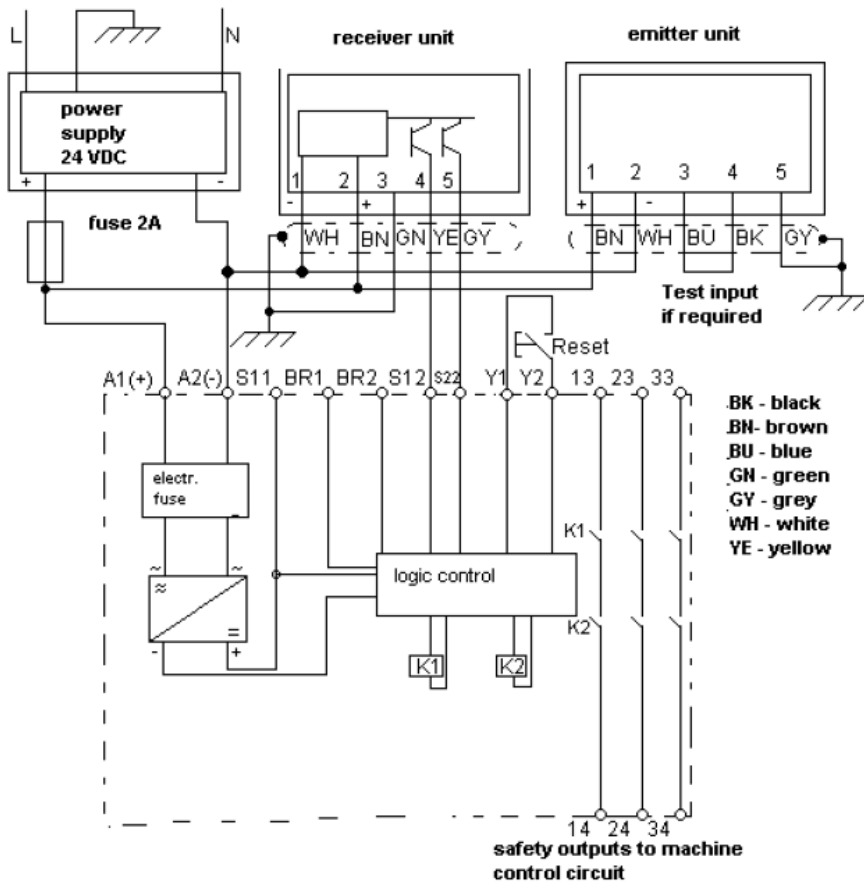
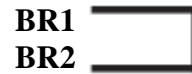

Figure 47- Cross-monitoring of MPCEs –Auto Reset



The diagram shows manual reset function with the B-Series guard. For automatic reset put a link between the contacts



and an additional link between



Figure 48 – SRUS Connection Details

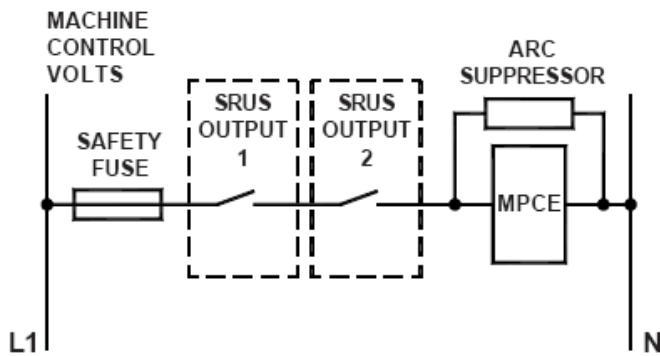

Figure 49 – Safety Output Connection (Single MPCE)

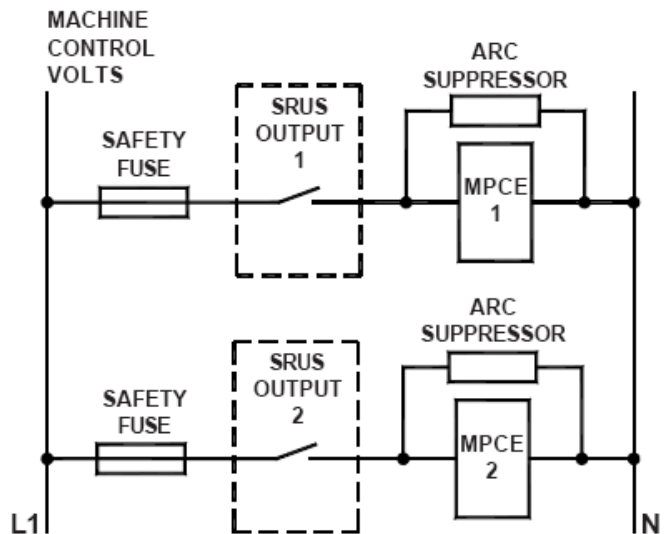

Figure 50 - Safety Output Connection (Two MPCEs)

5.0 TECHNICAL SPECIFICATION

Operating Voltage	24VDC +/- 10%
Power Consumption	approx. 2.5 VA
Response Time	< 30ms
Temperature Range: Operating	-25°C to +55°C
Reset Function	Manual or Auto
Contact Configuration	3 x N/O safety contacts
Contact Type	Relay positive guided
Max. Switching Capacity	1500VA (resistive load)
Max. Switching Capacity	250VAC, 24VDC
Switching Current	6A AC, 6A DC
Enclosure: Protection Rating Terminal Capacity Material	DIN 40050 (Terminal IP20) (Housing IP40) 2 x 2.5mm² solid wire DIN 26206 or 1 x 1.5mm² stranded wire with ferrule DIN 46228 Self-extinguishing according to UL 94 V-0

APPENDIX E – C6 MULTIFUNCTION INTERFACE CONTROLLER

1.0 PRODUCT DESCRIPTION

The C6 Multifunction Interface Controller serves as an interface between various Tapeswitch low-voltage sensors and an end-user device (machine and/or process control). It is ideal for existing machines in end-user and OEM applications. The C6 Multifunction Interface Controller is designed to monitor up to six sensor zones comprised of a combination of 1 to 3 B-Series Light Curtains and/or 1 to 6 other sensing devices. It provides the necessary power to the B-Series emitter and receiver units, and monitors the output signals. In addition to the light curtains, the C6 is specifically engineered for operation with various pressure-sensitive, normally-open switches such as ribbon switches, sensing edges/ bumpers and switching mats.

The C6 Controller provides constant monitoring of all sensing devices. In the event of a failure within a sensor or its cable (open or short circuit), the controller automatically detects the failure. In addition to the ability to detect a failure within the sensor or its cabling, the C6 is designed to detect a failure within the controller itself. The C6 Controller is a fully self-contained unit within a metal enclosure. See **Figure 51**. It is intended to be wall mounted and has six knockouts capable of accepting standard 1/2" or 3/4" conduit. It will accept an input power of source range of 85 to 264VAC at an input frequency range of 47 to 63 Hz. The unit will also accept a regulated 24VDC supply.

The C6 Controller provides the option of setting each zone for automatic or manual reset. To manually reset the controller, a key switch is provided on the front panel.

The controller provides two redundant safety output relay contacts (dry contact or voltage free) in which the output can be configured as normally-open (closed when the relay is energized) or normally-closed (open when the relay is energized). When the output relays are configured as normally-open, the two closed contacts will open when the sensing device is actuated (i.e., safety mat is stepped on), or should a fault occur within the safety device, or in the event that the power is removed. The outputs will remain open until the sensing device is clear and reset is applied. When the output relays are configured as normally-closed, the two open contacts will close when the sensing device is actuated (i.e., safety mat is stepped on), or should a fault occur within the safety device, or in the event that the power is removed. The outputs will remain closed until the sensing device is clear and reset is applied.

When the zone(s) is set in Manual Mode, the safety outputs will remain open until the sensing device is clear and a reset signal is applied. When the zones are set to AUTO, the safety outputs will reset automatically after the sensing device is clear.

Each of the six zones is equipped with three indicator lights: Manual Mode, Output On and Output Off, providing the status of each zone. The C6 Controller also has non-safety monitor output relays for each zone. They are Form C (normally-open, common, normally-closed) contact arrangements. The monitor relays are intended for status purposes only.

2.0 INSTALLATION INSTRUCTIONS

A complete technical description of the C6 Multifunction Controller, including installation instructions, can be found in the separate C6 Technical Manual which comes with the unit (part number 0480).

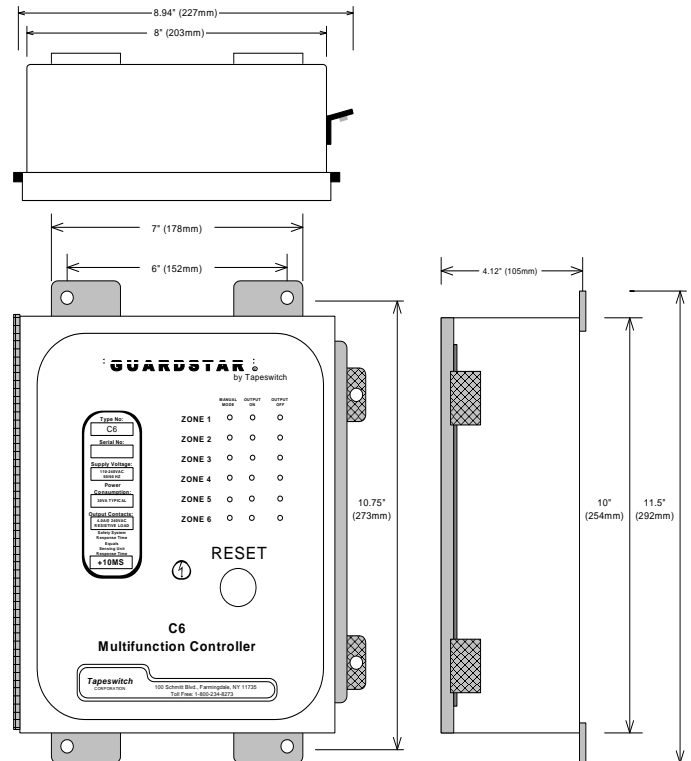

Figure 51 – C6 Multifunction Controller Outline Drawing

APPENDIX F – BC-1 BLANKING INTERFACE CONTROLLER

1.0 PRODUCT DESCRIPTION

The BC-1 Blanking Interface Controller is a device that performs as an interface between a Tapeswitch B-Series Light Curtain System and the protected machine. It includes provisions for programming the blanking function of a B-Series system. The BC-1 is basically a BSRSA Interface Controller with a BPU-2 Programming Unit incorporated into a single enclosure.

The BC-1 Controller has five indicators, two buttons, one reset key switch, and one program key switch. The front panel of the BC-1 is shown in **Figure 52**.

Four of the indicators are associated with the four types of blanking:

- no blanking
- learned (fixed) blanking
- 1 beam floating blanking
- 2 beam floating blanking

Because these can be used in combination there are six possible programmed modes:

- no blanking
- learned (fixed) blanking
- 1 beam floating blanking
- 2 beam floating blanking
- learned with 1 beam floating blanking
- learned with 2 beam floating blanking

2.0 INSTALLATION INSTRUCTIONS

A complete technical description of the BC-1 Blanking Interface Controller, including installation instructions, can be found in the separate BC-1 Technical Manual which comes with the unit (part number 0959).

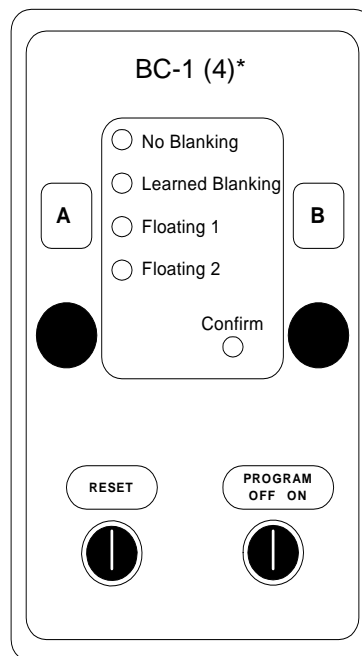

Figure 52 – BC-1 Blanking Controller Front Panel

***Note: Light Curtains ending with serial number D01 and above require BC-4 Blanking Unit**

APPENDIX G – BPU-2 BLANKING PROGRAMMING UNIT

1.0 PRODUCT DESCRIPTION

The BPU2 programming unit is required to program the blanking function of a B-Series Light Curtain System. It derives 24VDC operating power from the light curtain system, when it is hooked up.

The BPU2 unit has two 3 foot cables. One cable has an 8-pin male connector and the other has an 8-pin female connector. The unit is designed to be connected in line with the receiver/machine interface cable as illustrated in **Figure 53** below. It communicates exclusively with the B-Series receiver unit while it is connected to the system. The means of communication is serial data. While the BPU-2 is connected to the B-Series system, the outputs of the B-Series are always off and therefore the machine is not permitted to operate or cycle.

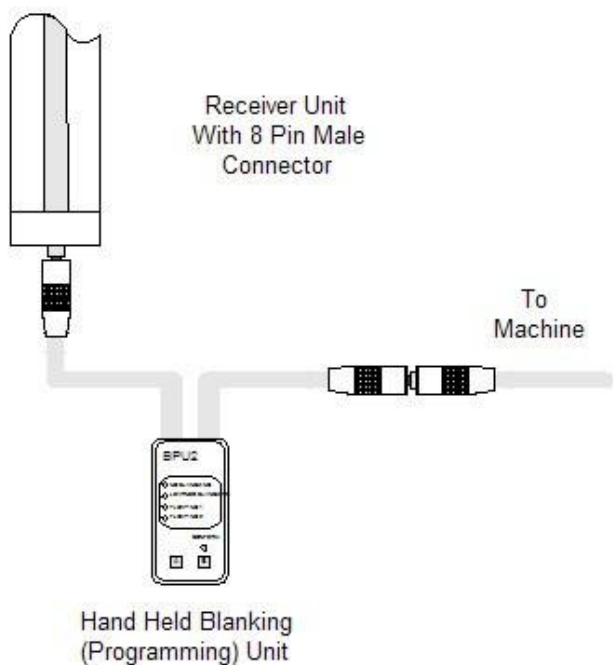

Figure 53 – BPU-2 Connected to B-Series Receiver

The BPU2 has five indicators and two buttons. The front panel of the BPU2 is shown in **Figure 54**.

Four of the indicators are associated with the four types of blanking:

- no blanking
- learned (fixed) blanking
- 1 beam floating blanking
- 2 beam floating blanking

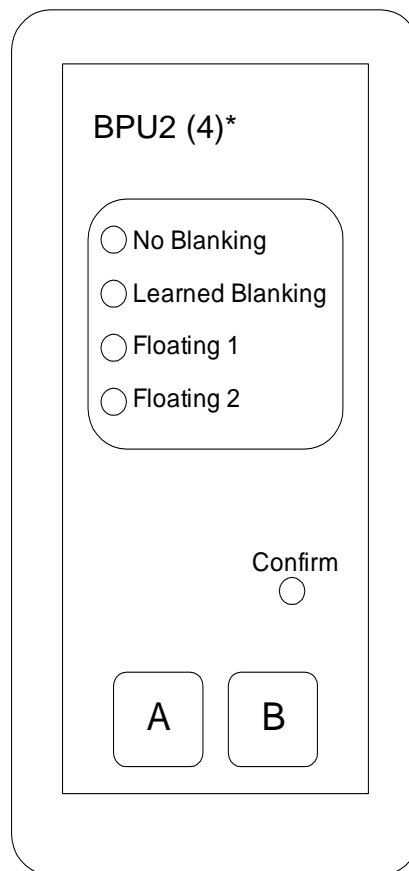

Figure 54- BPU-2 Front Panel

Because these can be used in combination there are six possible programmed modes:

- no blanking
- learned (fixed) blanking
- 1 beam floating blanking
- 2 beam floating blanking
- learned with 1 beam floating blanking
- learned with 2 beam floating blanking

2.0 INSTALLATION INSTRUCTIONS

A complete technical description of the BPU-2 Blanking Programming Unit, including installation and programming instructions, can be found in the separate BPU-2 Technical Manual which comes with the unit (part number 0953).

***Note: Light Curtains ending with serial number D01 and above require BPU-4 Blanking Unit**

APPENDIX H – GDC-1 24 VDC POWER SUPPLY

1.0 PRODUCT DESCRIPTION

The GDC-1 power supply converts an ac voltage input to +24VDC, which can be used to power a B-Series light curtain (emitter and receiver) and an SRUB Controller. It will accept a wide range of input voltages, from 85 to 264VAC, automatically. No jumpers or voltage strapping is necessary. The ac input is fuse-protected against current surges or short circuits within the high-voltage side of the unit.

A green LED will illuminate, indicating that +24VDC is present. The +24VDC output voltage is adjustable with a small Philip’s head screwdriver. The output voltage should be adjusted with a calibrated meter, once all of the loads are connected. The dimensions and terminal markings are shown in **Figure 55**. The Technical Specifications are shown in **Figure 56**.

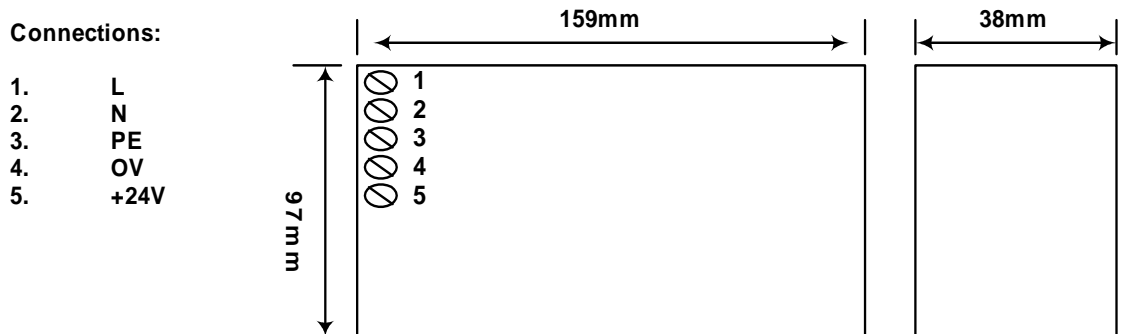
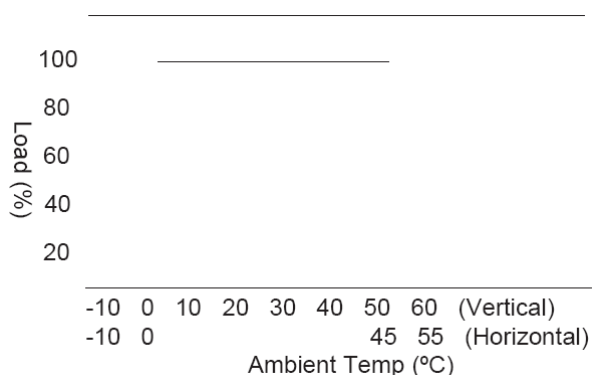
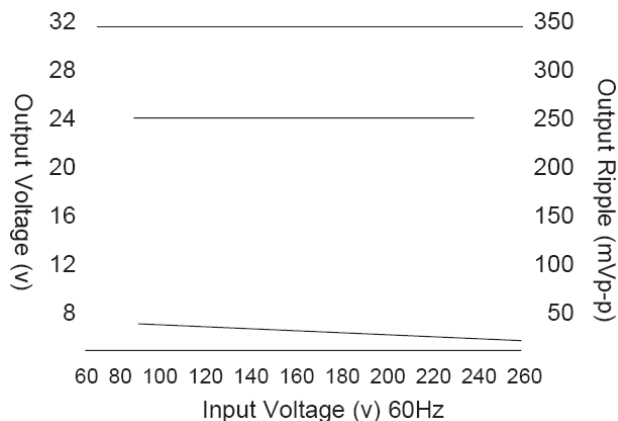

Figure 55 GDC-1 Dimensions and Terminal Markings

Output Derating



Static Characteristics



Input voltage	85-264 AC
Input frequency	47-63 Hz
Input current	2A/115V 1A/230V
Inrush current	2.5A/115V 0.5A/230V
Output voltage	24V DC adj +/- 10%
Output current	2.5A
Ripple	100mV P-P
Line regulation	+/- 0.2%
Load regulation	+/- 0.2%
Overload protection	105%-150% rated load current automatic recovery
Over voltage protection	115%-135%
Operating temperature	-10°C to +60°C
Dielectric strength	3KV VP-O/P (1 min)
Weight	550g
Safety standards	UL1012, TÜV EN60950, IEC950, UL1950
EMC standards	CISPR22 (EN55022) IEC801-234 IEC555-2 CISPR22

Figure 56 – GDC-1 Technical Specifications

APPENDIX I – LAT LASER ALIGNMENT TOOL

1.0 PRODUCT DESCRIPTION

The Laser Alignment Tool provides a visual indication of the alignment between a B-Series emitter and receiver. It is particularly useful for long range installations and installations requiring mirrors. The Laser Alignment Tool simply snaps into one of the B-Series sensing units (emitter or receiver). See **Figure 57**. It projects a beam of light across the sensing field and places a targeting dot on the (emitter or receiver). The dot gives the installer visual feedback on the accuracy of the alignment. The laser can be focused by simply rotating the beam projection head. The beam is kept on by applying inward pressure to the projector head until the “on” switch actuates.

For optimum alignment, the laser target dot should be located at the center of the clear lens of the emitter or receiver. Initially, the target dot may not land on the emitter or receiver at all. In this case, place a sheet of cardboard or a similar target behind the unit in order to provide a larger area for the laser dot to land. Once the laser dot is found, it will give the installer an indication as to which direction the sensing units need to be adjusted.

The Laser Alignment Tool is for initial set-up ONLY. It can not be used during normal machine operation since it will obstruct the light curtain. The laser MUST NOT BE POINTED OR DIRECTED TOWARDS ANY PERSONS. **Figure 58** shows the outline dimensions, and **Figure 59** lists the technical specifications.

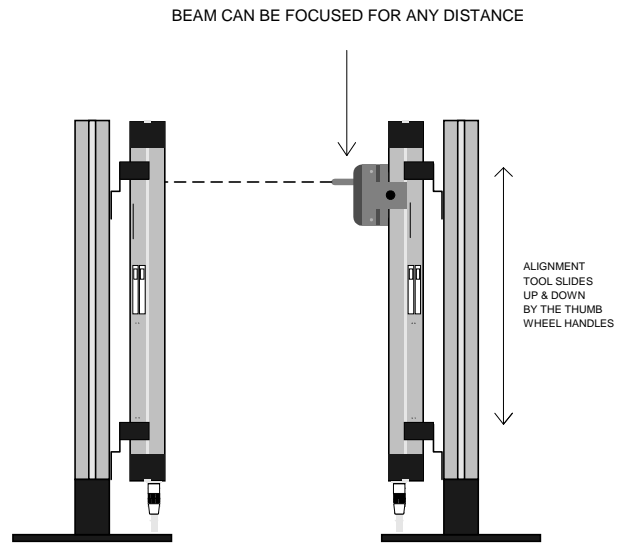

Figure 57 – LAT Alignment Tool Setup

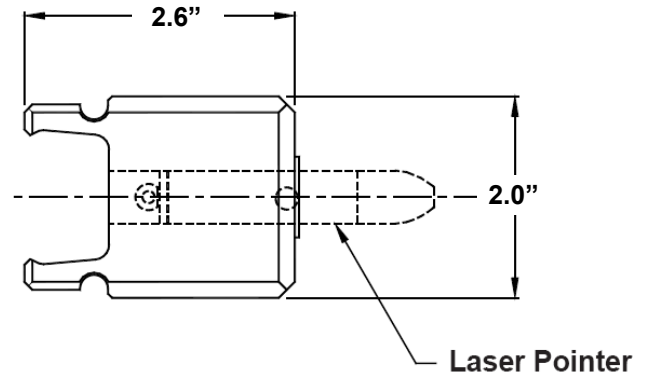

Figure 58 – LAT Dimensions

Laser Type	Class IIIa Laser Diode
Maximum Output	<5mW
Wavelength:	640nm (± 10)
Beam Diameter	Adjustable
Power Requirements	2-LR44 Alkaline batteries (incl)
Operating Time	2.5 hours continuous
Dimensions	0.40" Dia x 2.5" L
Weight	2.0 oz. with batteries
Switch	Momentary On/Off

Figure 59 – LAT Technical Specifications