



# C6 Multifunction Interface Controller

## Technical Manual

### **WARNING**

Tapeswitch safety systems are intended to protect operators working at or near dangerous machinery. They can only perform this function if they are correctly fitted to a suitable machine. It is essential that the full contents of this manual and all the international documents referred to herein are fully understood before any attempt at installation is made. If in doubt, contact Tapeswitch Corporation.

### **IMPORTANT**

This manual must accompany the product throughout its working life. Those persons responsible for the product must ensure that all persons involved in the installation, commissioning, operation, maintenance and servicing of the product have access to all the information supplied by the manufacturers of the machine and its safety system.

## CONTENTS

	<b>Page</b>
<b>1. INTRODUCTION</b>	<b>3</b>
<b>2. METHODS OF INTERFACING</b>	<b>3</b>
<b>3. ELECTRICAL CONNECTIONS</b>	<b>4</b>
3.1 Reset, Manual/Automatic	
3.2 Pressure Sensitive Sensor(s) Connections	
3.3 Mechanical	
3.4 Power Connection	
<b>4. OPERATION SEQUENCE AND LED STATUS DESCRIPTION</b>	<b>11</b>
4.1 Manual Reset	
4.2 Automatic Reset	
4.3 Monitor Output	
4.4 Printed Circuit Board LEDS	
<b>5. OUTLINE DRAWING</b>	<b>13</b>

## C6 Multifunction Interface Controller

***When used with Light Curtains; also see the B-Series Technical Manual***

### 1. Introduction

The C6 Multifunction Interface Controller acts as an interface between various Tapeswitch low voltage sensors and the end-user device (machine and/or process control). It is ideal for existing machines and end-user and OEM applications. The C6 Multifunction Interface Controller is designed to incorporate up to six sensor zones comprised of a combination of 1 to 3 B-Series Light Curtains and/or 1 to 6 sensing products. It provides the necessary power to the B-Series sensing unit emitter and receiver, and monitors the output signals from the B-Series sensing unit. In addition to the light curtains, the C6 is specifically engineered for operation with various pressure sensitive, normally open switches (ribbon switches, sensing edges/ bumpers and switching mats).

The C6 Controller provides constant monitoring of the sensing device. In the event of a failure within the sensor or its cable (open or short circuit) the controller automatically detects the failure. In addition to the ability to detect a failure within the sensor or its cabling, the C6 is designed to detect a failure within the controller itself. The C6 Controller is a fully self-contained unit within a metal enclosure. It is intended to be wall mounted and has six knockouts capable of accepting standard 1/2" or 3/4" conduit. It will accept an input power of source range of 85 to 264 VAC at an input frequency range of 47 to 63Hz. The unit will also accept a regulated 24 VDC supply.

The C6 Controller provides the option of setting each zone for automatic or manual reset. To manually reset the controller, a key switch is provided on the front panel.

The controller provides two redundant safety output relay contacts (dry contact or voltage free) in which the output can be configured as normally open (closed when the relay is energized) or normally closed (open when the relay is energized). When the output relays are configured as normally open, the two closed contacts will open when the sensing device is actuated (i.e., safety mat is stepped on), or should a fault occur within the safety device, or in the event that the power is removed. The outputs will remain open until the sensing device is clear and reset is applied. When the output relays are

configured as normally closed, the two open contacts will close when the sensing device is actuated (i.e., safety mat is stepped on), or should a fault occur within the safety device, or in the event that the power is removed. The outputs will remain closed until the sensing device is clear and reset is applied.

When the zone(s) is set in Manual Mode the safety outputs will remain open until the sensing device is clear and a reset signal is applied. When the zones are set to AUTO, the safety outputs will reset automatically after the sensing device is clear.

Each of the six zones is equipped with three indicator lights: Manual Mode, Output On and Output Off, providing the status of each zone. The C6 Controller also has non-safety monitor output relays for each zone.

They are Form C (normally-open, common, normally-closed) contact arrangements. The monitor relays are intended for status purposes only.

### 2. Methods of Interfacing

The C6 Controller has two safety outputs. These outputs are to be interfaced with the machine primary control elements (MPCE's). An MPCE is defined as an electrically controlled element which directly controls the normal operating motion of a machine such that it is the last (in time) to operate when motion is initiated or arrested.

The safety output contacts of the C6 Interface Unit must be connected to a machine's MPCE's in such a way that if either of the safety output relays is switched off, then the machine will be brought to rest, regardless of the state of the other relay.

This gives assurance that the failure of a single relay cannot prevent the machine from being stopped. The safety output relays are cross-monitored within the interface unit. This means any disparity between the two relays will be detected. The machine will be disabled until the cause of the disparity has been removed. Such a disparity could be the loss of signal on one of the two channels coming from the sensing unit. The interface will only allow the safety relays to move to the ON state if both channels are working correctly together.

**Both of these outputs must be used to take advantage of the inherent redundancy of the interface unit.**

The safety outputs can be used in several ways, depending on the MPCE's found on the machine being guarded. MPCE is the abbreviation for Machine Primary Control Element. An MPCE is an electrically powered control device which directly controls the guarded machines motion and is the final device in the operating sequence when motion is either initiated or halted. This would be the main hydraulic control valve in a hydraulically controlled press. Some of the common arrangements are described below:

• **Normal Risk Machine** - These usually have a single MPCE. In this case, both normally-open safety outputs should be used together, as shown in Figure 1.

• **High Risk Machines** - These should have 2 MPCE's. In some countries, it is customary for both MPCE's to operate in the same mode. In this case, each of the normally-open (NO) outputs controls a single MPCE. See Figure 2 for an illustration of this type of interface. Any additional output contacts can be used as a monitor, e.g., as an input to a PLC.

To protect the contacts of the safety output relays from the effects of switching inductive loads, an appropriately rated power factor correction device must be installed for the MPCE coils. Figures 1 and 2 show 'Arc Suppressors' used for this purpose. They must not be fitted across the safety relay contacts. Arc Suppressors are user-supplied.

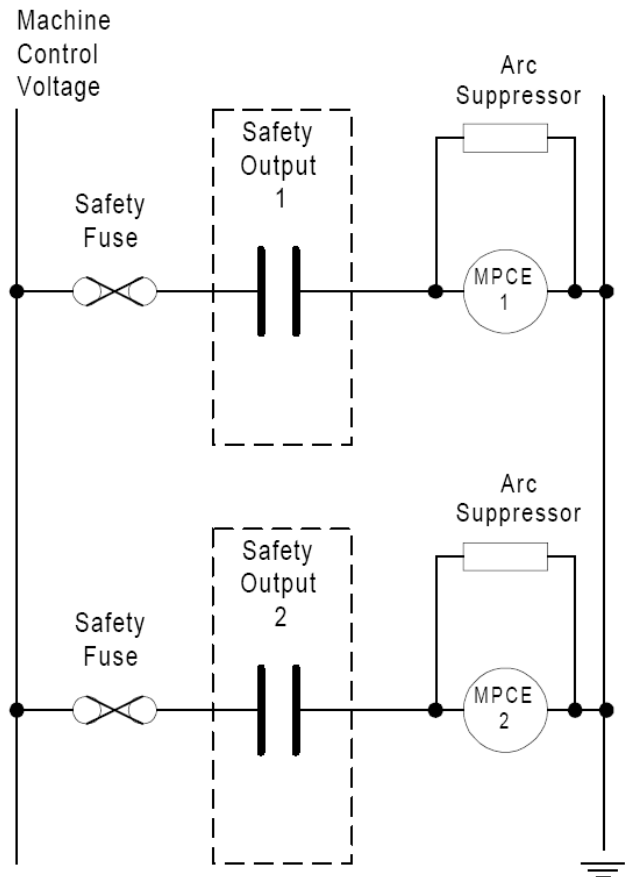

Figure 2 - Interfacing a Machine with Dual Identical MPCE's

**CAUTION**  
**Suppressors must not be connected across safety relay contacts.**

### 3. Electrical Connections

The C6 Controller has eight internal block connectors:

- Mat 1 / Guard 1
- Mat 2 / Guard 2
- Mat 3 / Guard 3
- Mat 4 / Mat 5
- Mat 6
- Safety O/P 1 / Safety O/P 2 / Monitor O/P 1
- Monitor O/P 3 / Monitor O/P 4 / Monitor O/P 5
- Monitor O/P 5 / Monitor O/P 6

Each terminal is mechanically suitable for (1) 2.5mm (14AWG) wire. Crimped ferrules or tinning must be used on all standard conductors.

**Note: All unused mat inputs must be linked out using jumper wires in order for the controller to operate (see the sensor wiring diagram, figure 4, for link outs). Unused light curtain inputs do not need to be linked.**

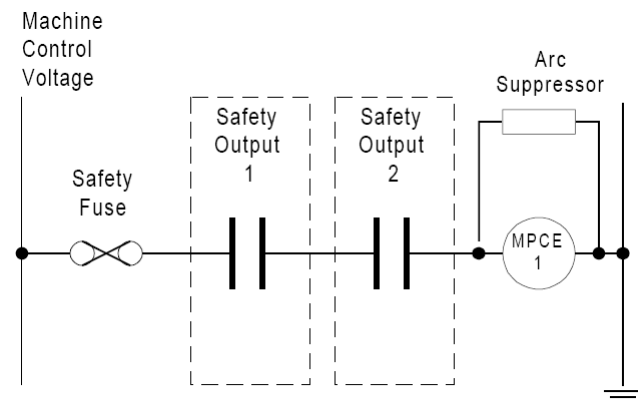

Figure 1 - Interfacing a Machine with 1 MPCE

The exact wiring requirements are at the discretion of the installer and depend to a large extent on the siting of the various control elements. Generally, it is recommended that high voltage cables be routed away from low voltage cables.

Figure 7 shows the System Block Diagram for the C6 Controller.

For light curtain installations the Wire Run List (WRL), Figure 8, will give the proper terminal numbers and associated functions for the cabling between the B-Series sensing unit (emitter and receiver) and the C6 Control Unit. Be sure to observe the color coding shown to assure proper operation. The cables for the interface between the B-Series Sensing Unit (emitter and receiver) and the C6 Unit are ordered separately. The emitter cable has five conductors with a black insulation jacket. The receiver cable has eight conductors with a black insulation jacket. The cables will only mate to the proper component of the sensing unit.

**3.1 Reset, Manual/Automatic**

The C6 is configured from the factory preset as an auto reset controller and the output contacts will resume their original states automatically once the activated sensor is cleared (i.e., person / object is removed from the safety mat). For applications where a manual reset is required, the C6 has P.C. Board mounted jumpers that change the reset function of a particular zone from auto reset to manual reset. This can be accomplished by removing the jumper for the zone you want changed. This manual reset function is available on all 6 zones. When a zone is in the manual reset mode, a Manual Mode Amber indicator light on the front panel will be illuminated to indicate the zone that is in manual reset. When the sensing device is activated, the output contact will remain open until the sensing device is clear and the controller is manually reset by the key switch.

In addition to the Amber Manual Mode indicator lamps, the front panel also has Green lamps that indicate Output On and Red lamps that indicate Output Off.

**3.2 Pressure Sensitive Sensor(s) Connection**

Connect the sensor cables to the C6 Control Unit in accordance with the Sensor Connection Wiring Diagram, taking particular care that there are no stray strands which could cause a short between the adjacent terminals. A number of sensors can be connected in series. See Figure 6 for details and limitations. When connecting a number of sensors in series, the C6 Controller treats these “combined” sensors as a single sensor. When any one of these sensors is actuated the output relays de-energize.

**3.3 Mechanical**

The metallic enclosure has six knockouts capable of accepting standard conduit fittings. It is recommended that any high voltage connection made to the C6 control Unit be made with suitable cabling and/or conduit protections. The connection between the C6 and the B-Series Sensing Unit (emitter and receiver) are non-hazardous low voltage signals and additional protection of these cables is not necessary. It is recommended that suitable fitting or cable grips be used to maintain the moisture integrity of the installation. **It is also recommended to separate the low voltage connections from the high voltage connections.** Local electrical codes should be observed.

**3.4 Power Connection**

The power supply P.C. Board is mounted to the inside of the metal enclosure door. The power supply is designed to accommodate an input voltage range of 88 to 132 VAC and 176 to 264 VAC and an input frequency range of 47 to 63Hz. Along the bottom edge of the P.C. Board is a terminal block CN1. Terminal block CN1 is the input power connection point for the C6 Controller. Supplied with the C6 Controller is a mating terminal block connector and pins to which the input power wires will be crimped to and inserted into the terminal block. Once the terminal block connector is assembled, it can be attached to the P.C. Board terminal block by inserting the connector into the terminal block, CN1. See Figure 3 below.

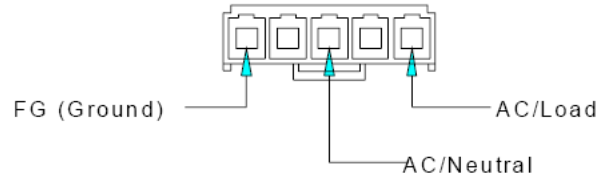

**Figure 3 - Connector**

SENSOR TYPE	SENSOR CONNECTION			
	A	B	C	D
Mats (single lead)	Red	White	Black	Yellow
Mats (dual lead)	White 1	White 2	Black 1	Black 2
Edges	Smooth 1	Smooth 2	Ribbed 1	Ribbed 2

All unused mat inputs must be linked out using jumper wires in order for the controller to operate, i.e. LINK A-B LINK C-D. If you are connecting a Guard to Guard #1 NO CONNECTIONS should be made to Mat #1. Same holds true for Guard #2 and Guard #3.

**Figure 4 - Sensor Wiring Diagram**

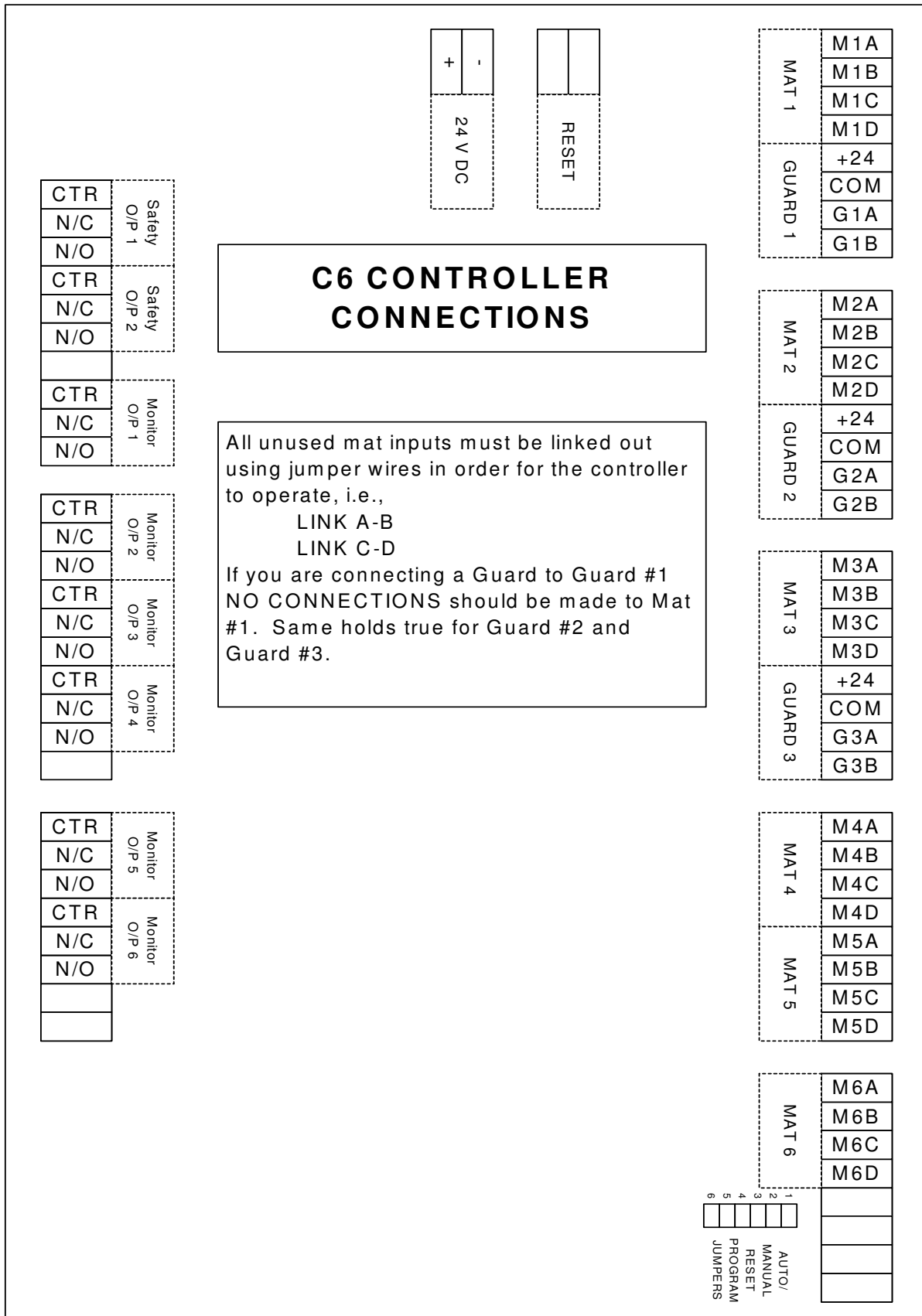
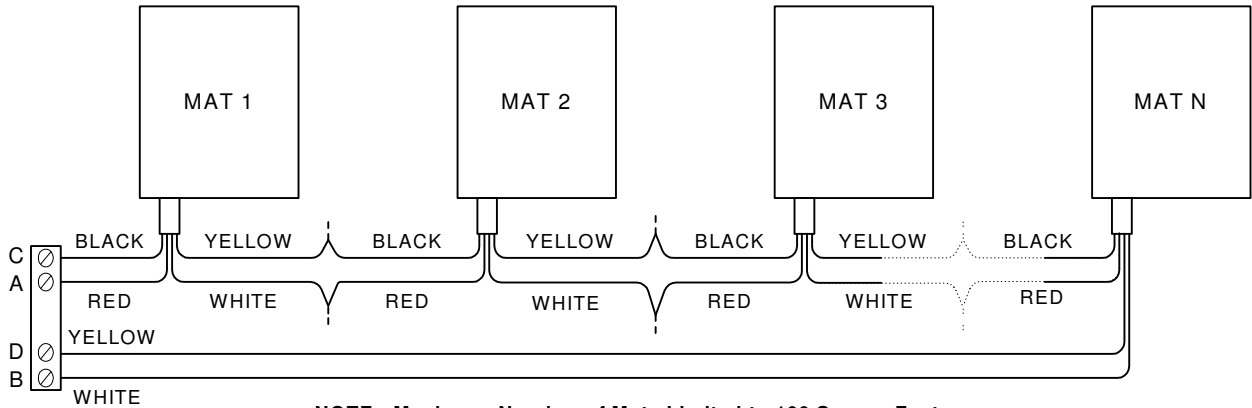

Figure 5 - PC Board Terminal Block Locations

**INTERCONNECT DIAGRAMS, DAISY CHAINED/SERIES CONNECTION**

**Multiple Mats with 4 Conductor Standard Color Coded Lead Wire**



**NOTE: Maximum Number of Mats Limited to 100 Square Feet**

**Multiple Mats with Optional 2 Conductor Standard Color Coded Lead Wire**

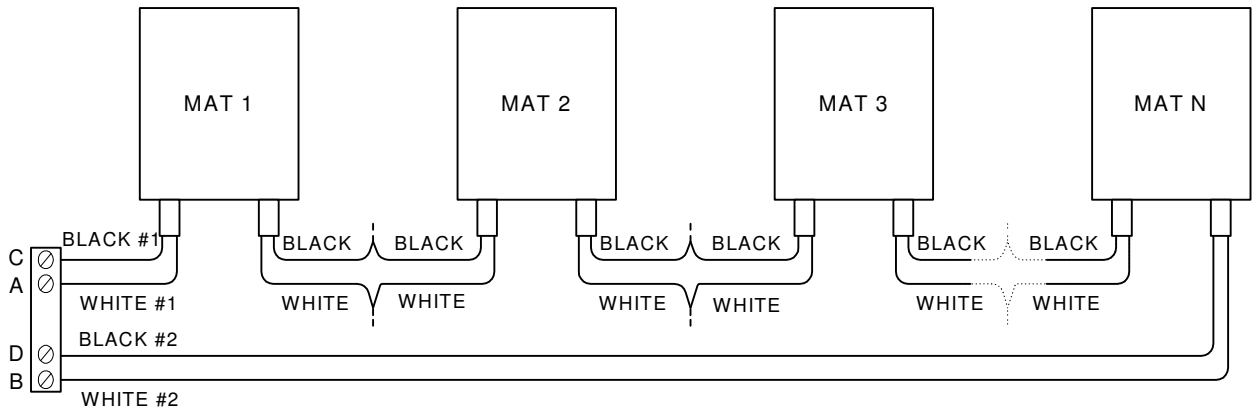

**Multiple Sensing Edges, Bumpers and Ribbon Switches with Color Coded Wire**

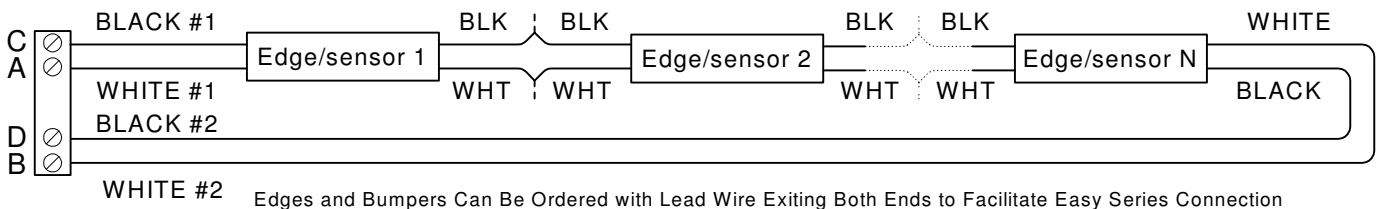

Edges and Bumpers Can Be Ordered with Lead Wire Exiting Both Ends to Facilitate Easy Series Connection

**NOTE: Maximum Number of Edges, Bumpers, and Ribbon Switches Limited to 200 Feet**

**Multiple Sensing Edges, Bumpers and Ribbon Switches with Non-Color Coded Zip Cord Wire**

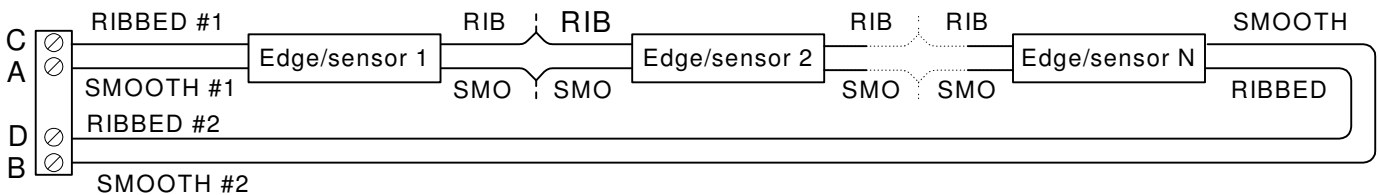

**Figure 6 - Multiple Sensor Connections**

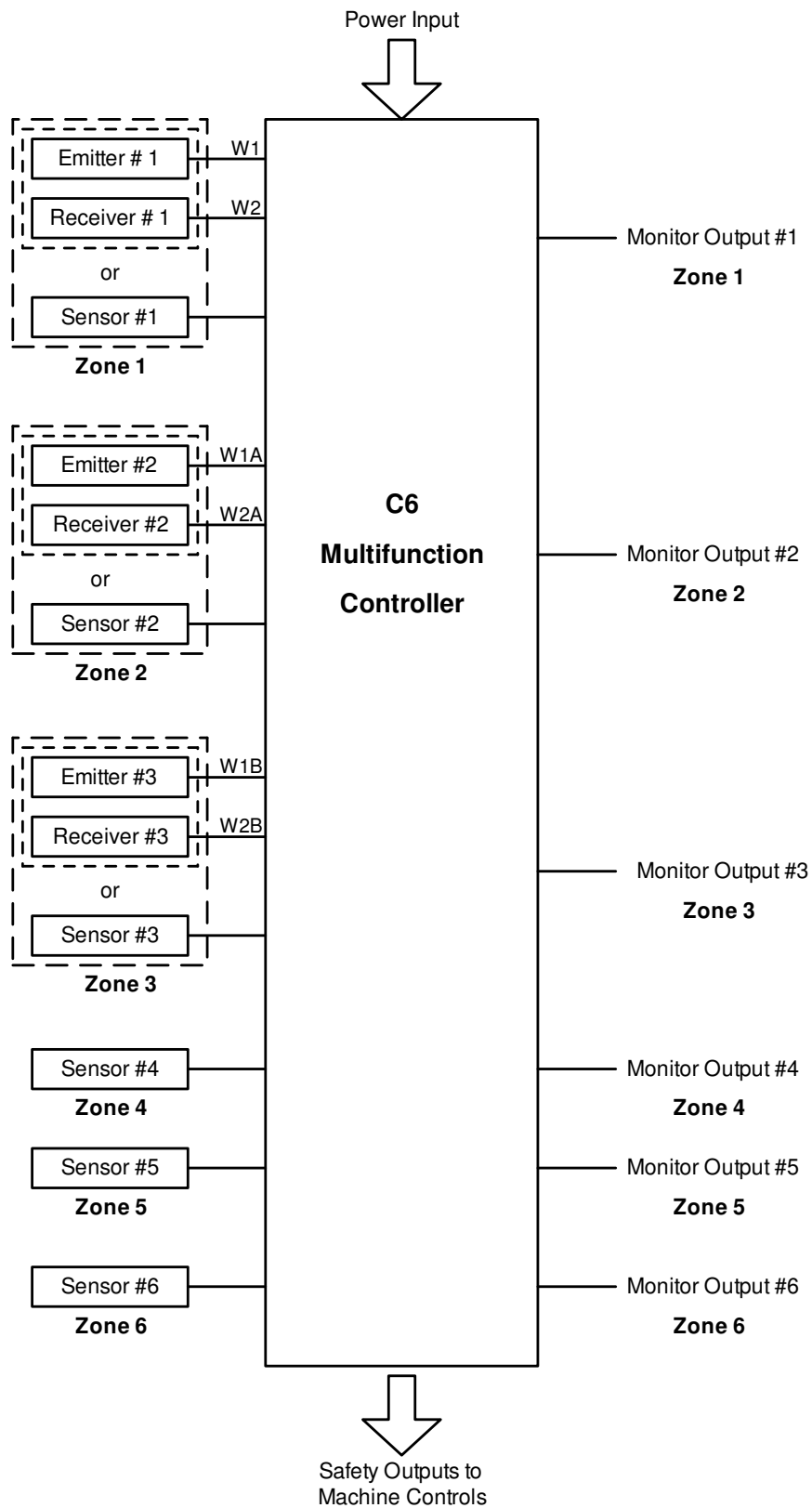

Figure 7 - System Block Diagram

**WIRE RUN LIST for the C6 Multifunction Controller  
Up to Three Light Curtain Configurations**

Cable #	Cable Type	Color Code	Function	From Light Curtain #1	C6 to Guard #1
	<b>RKT5-612/XX</b>			<b>Emitter 5 Pin Quick Disconnect</b>	
W 1	"	Brown	+24 VDC	1	+24
W 1	"	White	OV DC	2	COM
W 1	"	Blue	Test Out	TWIST PAIR TOGETHER Black & Blue Wire	No Connection
W 1	"	Black	Test In		No Connection
W 1	"	Gray	Ground	5	COM
	<b>RKT8-09/XX</b>			<b>Receiver 8 Pin Quick Disconnect</b>	
W 2	"	White	OV DC	1	COM
W 2	"	Brown	24 VDC	2	+24
W 2	"	Green	Ground	3	COM
W 2	"	Yellow	Output 1	4	G1A
W 2	"	Gray	Output 2	5	G1B
W 2	"	Pink	Data (-)	6} Isolate 6 & 7	No Connection
W 2	"	Blue	Data (+)	7} Isolate 6 & 7	No Connection
W 2	"	Shield	Ground	8	COM
Cable #	Cable Type	Color Code	Function	From Light Curtain #2	C6 to Guard #2
	<b>RKT5-612/XX</b>			<b>Emitter 5 Pin Quick Disconnect</b>	
W 1 A	"	Brown	+24 VDC	1	+24
W 1 A	"	White	OV DC	2	COM
W 1 A	"	Blue	Test Out	TWIST PAIR TOGETHER Black & Blue Wire	No Connection
W 1 A	"	Black	Test In		No Connection
W 1 A	"	Gray	Ground	5	COM
	<b>RKT8-09/XX</b>			<b>Receiver 8 Pin Quick Disconnect</b>	
W 2 A	"	White	OV DC	1	COM
W 2 A	"	Brown	24 VDC	2	+24
W 2 A	"	Green	Ground	3	COM
W 2 A	"	Yellow	Output 1	4	G 2 A
W 2 A	"	Gray	Output 2	5	G 2 B
W 2 A	"	Pink	Data (-)	6} Isolate 6 & 7	No Connection
W 2 A	"	Blue	Data (+)	7} Isolate 6 & 7	No Connection
W 2 A	"	Shield	Ground	8	COM

**Figure 8 - Wire Run List**

**WIRE RUN LIST for the C6 Multifunction Controller  
Up to Three Light Curtain Configurations (continued)**

Cable #	Cable Type	Color Code	Function	From Light Curtain #3	C6 to Guard #3
	<b>RKT5-612/XX</b>			<b>Emitter 5 Pin Quick Disconnect</b>	
W 1 B	"	Brown	+24 VDC	1	+24
W 1 B	"	White	OV DC	2	COM
W 1 B	"	Blue	Test Out	TWIST PAIR TOGETHER Black & Blue Wire	No Connection
W 1 B	"	Black	Test In		No Connection
W 1 B	"	Gray	Ground	5	COM
	<b>RKT8-09/XX</b>			<b>Receiver 8 Pin Quick Disconnect</b>	
W 2 B	"	White	OV DC	1	COM
W 2 B	"	Brown	24 VDC	2	+24
W 2 B	"	Green	Ground	3	COM
W 2 B	"	Yellow	Output 1	4	G 3 A
W 2 B	"	Gray	Output 2	5	G 3 B
W 2 B	"	Pink	Data (-)	6} Isolate 6 & 7	No Connection
W 2 B	"	Blue	Data (+)	7} Isolate 6 & 7	No Connection
W 2 B	"	Shield	Ground	8	COM

**Figure 8 - Wire Run List (continued)**

## 4. Operational Sequence and LED Status Description

**Note:** The LEDs on the C6 provide status indication for the output state of the safety relay in relation to each of the six zones. The LEDs also indicate what zones are in Manual Mode.

### RESETTING OPTIONS

The C6 Interface can be configured for a manual (latched) reset or automatic reset. In the manual reset mode the safety outputs will go to the “off” state once the light curtain is obstructed and **remain** in the “off” state until the obstruction is removed and the reset key switch is activated. Once this reset sequence is followed the safety outputs will resume the “on” state. In the automatic reset mode the safety outputs will follow the state of the light curtain or sensor (i.e., light curtain clear: outputs “on”, light curtain obstructed: outputs “off”.) The following operational sequence will be described for both reset options.

#### 4.1 Manual Reset

When power is first applied to the C6 Controller:

1.) The amber Manual Mode lights (only for the zones in Manual Mode) will be illuminated and no other lights will be illuminated until the key switch reset is initiated.

2.) Once the key switch reset is initiated, the six green LEDs (zones 1 through 6) will illuminate. This is provided the system is properly wired, no faults exist and the sensors are clear and or the B-Series sensing units (emitter and receiver) have power and are properly aligned. All safety relay outputs will be in the “on” state. The green LEDs on the C6 Controller indicate that all the zone safety outputs from the sensors and/or B-Series sensing units are functioning. All of the green LEDs must be illuminated in order for the safety output relays to be in the “on” state.

3.) These outputs will remain “on” until a zone(s) sensor(s) is activated and/or the light curtain(s) is obstructed, faulty or misaligned. If an activation and/or obstruction occurs in a zone(s), the green LEDs (Output On) will go off and remain off and the red (Output Off) light(s) will flash. The green LEDs will remain off (even if the sensors and or light curtain is cleared) until the key switch reset is applied.

4.) Once the reset is applied, the flashing red light(s) for the activated zone(s) will turn off and the six green LEDs will illuminate and the safety output relays will also go to the “on” state.

#### 4.2 Automatic Reset

When power is first applied to the C6 Controller:

1.) Power is automatically applied to sensors and or light curtains (emitters and receivers) and if the system is properly connected and aligned (see the following wiring information) and the sensing units are clear with no faults, the C6 Controller should have six green “Output On” LEDs illuminated.

**Note:** When the C6 Controller is set in the Automatic Reset Mode, the Manual Mode amber lights will NOT be illuminated.

These green LEDs indicate the output status (zones 1 through 6) is “on” and the redundant output safety relays are in the “output on” state (normally open or normally closed depending on wiring hook-up choice). The outputs will remain “on” until an obstruction or fault occurs in any of the sensing units and/or light curtains (emitter or receiver pairs). When a sensing unit zone is activated the corresponding red LED “Output Off” will illuminate and flash. These LEDs indicate the output status (both redundant safety outputs are off) and also identify which sensing zone has been activated.

Zone 1 Red flashing indicates that sensing unit one has been activated and Zone 2 Red flashing indicates that sensing unit two has been activated, etc. For the zones, which are not activated, the Green LED output status will remain lit steady. It is important to note that the Green LED status indicators may be illuminated, however, the redundant safety outputs may actually be off as a result of the other zone sensing unit being activated. This is designed to assist the user as to which sensing unit zone has caused the output to go to the off state. The outputs will remain open until the sensor and or light curtain is clear. The outputs follow the state of the sensor and or light curtain and reset AUTOMATICALLY without any operator intervention. It is important to note the C6 does not distinguish between a light curtain fault, obstruction, misalignment or improper wiring. All of these conditions cause the C6 to respond as if the sensor is activated and or the light curtain is obstructed and the redundant safety outputs will be in the off state.

### 4.3 Monitor Output

Non-safety monitor outputs are also provided for all six zones. These outputs can be configured either normally open or normally closed. The monitor outputs should be wired in such a way to indicate the status of both safety output relays. As an example, if both safety outputs are connected as normally open (contacts closed when the mat and or light curtain is clear) the monitor relay output should be wired as normally closed. Therefore, when the safety outputs are open (contacts open when the mat and or light curtain are activated), the monitor outputs will be closed. These outputs can be used for non-safety related functions such as displays and status indications. It must not be used for safety related machine control and switching functions.

### 4.4 Printed Circuit Board LEDS

On the main printed circuit board, adjacent to the sensor/ light curtain terminal blocks are a series of red LEDS. The LEDS are placed in pairs to coincide with the location of the inputs of the sensors and light curtains. The purpose of these LEDS is to indicate the status of the sensing device that is being used. If both LEDS are illuminated, this indicates that the sensing device is open or clear. If both LEDS are off, this indicated that the sensing device is closed or blocked. If only one of the LEDS is illuminated, this indicates that there is a problem with the sensor wiring or sensor (mat, edge, and bumper, etc.). In a light curtain application a single LED will indicate that one of the receiver outputs is inoperative or not connected.

## C6 - TECHNICAL SPECIFICATIONS

<b>MODEL STYLE</b>	<b>C6 Multifunction Controller</b>
<b>Part Number</b>	0480
<b>Supply Voltage</b>	110-240 VAC 50/60 Hz or 24 VDC
<b>Power Consumption</b>	30VA TYPICAL
<b>Enclosure Type</b>	Metal Wall Mount
<b>Protection Rating</b>	NEMA 1 Standard / IP10, NEMA 12 Optional / IP52
<b>Weight</b>	9.5 lbs. (4.3 kg)
<b>Sensor Wiring</b>	Fail-Safe
<b>Reset Mode</b>	Automatic (supplied) or Manual Reset or Combination
<b>Outputs Relays</b>	Forced Guided Safety Relays
<b>Output Contacts</b>	6.0A @ 240 VAC Resistive Load
<b>Monitor Output</b>	Non-Safety 6 X (N/O or N/C) Selectable, 10A @ 250 VAC Resistive
<b>Applications</b>	Light curtains, ribbon switches, sensing edges/bumpers, switching mats
<b>Operating Temperature</b>	0 °C to 50 °C
<b>Response Time</b>	10ms

### 5. Outline Drawing

