



ControlMat Safety Mat Installation Manual

WARNING

Tapeswitch safety mat systems are intended to detect operators working at or near dangerous machinery and to send a signal to the safety control system. They can only perform this function if they are correctly fitted to a suitable machine. It is essential that the full contents of this manual and all the authoritative documents referred to herein are fully understood before any attempt at installation is made. If in doubt, contact Tapeswitch Corporation.

IMPORTANT

This manual must accompany the product throughout its working life. Those persons responsible for the product must ensure that all persons involved in the installation, commissioning, operation, maintenance and servicing of the product have access to all the information supplied by the manufacturers of the machine and its safety system.

Check our web site at www.tapeswitch.com for any corrections or addendums to this manual since its publication.

NOTE

The following procedures apply to the instructions contained in this manual and reference copies should be made available to personnel involved in installation of the safety system.

ISO 13849-1 (EN954-1): Safety of machinery – Safety related parts of control systems – Part 1: General principles for design.

EN999: Safety of machinery – Positioning of protective equipment in respect to approach speeds of parts of the human body.

EN1760-1: Safety of machinery – Pressure-sensitive protective devices – Part 1: Pressure sensing mats and floors.

ANSI B11.19: Performance Criteria for Safeguarding

B11.TR3: Risk Assessment and Risk Reduction

TABLE OF CONTENTS

	Page
1. INTRODUCTION	2
2. PACKAGING, HANDLING, TRANSPORTATION AND STORAGE	2
2.1 Packaging, Unpacking and Handling	2
2.2 Transportation	2
2.3 Storage	2
3. PRODUCT DESCRIPTION	3
3.1 Mat Shapes and Sizes	3
3.2 Inactive Zone	3
3.3 Lead Options	3
3.4 Edging Options	3
4. TECHNICAL DESCRIPTION	3
4.1 System Overview	3
4.2 Mat Design	3
4.2.1 Internal Construction	3
4.2.2 Chemical Resistance	4
4.2.3 Combining of Sensors	4
5. MAT SIZE AND LOCATION	5
5.1 General Considerations	5
5.2 Minimum Active Distance	5
5.3 Calculating Minimum Active Distance	5
5.3.1 Calculation Example	6
6. INSTALLATION	6
6.1 General Information	6
6.2 Mat Installation	7
6.2.1 Mat Mounting Surface	7
6.2.2 Edging Options	7
6.2.3 Lead Wiring Options	10
6.2.4 Installation Procedure	11
7. COMMISSIONING CHECKS	11
8. CLEANING AND MAINTENANCE	12
9. SPECIFICATIONS	13
10. TROUBLESHOOTING GUIDE	14
10.1 Mats with Single 4-Conductor Lead	14
10.2 Mats with Two 4-Conductor Leads	14
10.3 Mats with Two 2-Conductor Leads	15

1. INTRODUCTION

The **TAPESWITCH ControlMat Safety Mat** is a pressure-sensitive safety device designed to protect operators working at or near dangerous machinery. The mat functions as a momentary-contact, normally-open switch which is closed when anyone is standing on it.

Multiple safety mats may be wired in series to form a large protected area. In a 4-wire mat system, a small dc current flows through the upper and lower conductors of the ribbon switch sensors at all times. This current is used by the safety interface controller/safety interface module (SIM) to continuously monitor mat integrity.

When an actuating force is applied anywhere in the active area of the mat, the ribbon switch closes, which, in turn, causes a signal to be sent to the interface controller to shut down the guarded machine.

If any of the connecting wiring, internal or external to the mat should break or separate, this is detected by the controller and it shuts down the machine. A short causes the same result, and, thus the machine cannot run unless there is integrity in all mats and the interconnecting wiring.

Tapeswitch ArmorMats meet the applicable requirements for actuating force as defined in Standards EN 1760-1 and ANSI/RIA 15.06. That is, the mat will respond to a force of 66 lbs (30 kg) when applied to a flat disc 3.125" (80 mm) in diameter anywhere on the active area.

NOTE

ControlMat Safety Mats, individually or wired together, do not by themselves constitute a complete safety system. **The user must also select a safety interface controller/safety interface module (SIM) that complies with annex B of ISO 13849-1 (EN954-1) and the guidelines in ANSI B11.19.**

This controller must include dual channel monitoring such that a single electrical failure in the mat, interconnecting wiring, or the control unit itself will be detected and will shut down the machine.

This will establish a complete safety machine interface system. In addition, the category rating will then be at the level of the attached controller to a maximum category level of 3. Categories are defined in accordance with safety standard ISO 13849-1 (EN 954-1) for pressure-sensitive mats and pressure-sensitive floors.

When correctly installed at and interfaced to a machine, the ControlMat Safety Mat will:

- (a) Detect a person present in the dangerous area and prevent dangerous motion from occurring.
- (b) Detect a person entering the dangerous area and cause dangerous motion to cease before the person can reach the dangerous parts.
- (c) A combination of (a) and (b). The area covered by the ControlMat Safety Mat depends on which of the functions (a), (b) or (c) is to be performed.

The ControlMat Safety mat is not suitable for detecting walking aids, e.g. sticks and walking frames.

2. PACKAGING, HANDLING, TRANSPORTATION, and STORAGE

2.1 Packaging, Unpacking, and Handling

Depending on the size and weight, ControlMat Safety Mats are packaged either in a wooden frame container with a triple-wall cardboard top and bottom, or in a suitable corrugated box. Multiple mats may be stacked in a single box. For larger mats and mat systems multiple boxes can be attached to wooden skids for re-enforcement. The mats weigh approximately 3.5 lbs. per square foot.

Because of the weight, size, and flexibility of the individual mats, unpacking requires more than one person. Keep the mats flat at all times. **DO NOT ROLL, COIL OR FOLD THEM. DO NOT LIFT OR PULL A MAT BY THE LEADS.**

2.2 Transportation

When shipping a mat, use the original or similar packaging to prevent damage. Mat crates can be transported by common carrier or parcel service (size permitting). The crate should be kept flat and should not be transported on its side for an extended period of time.

2.3 Storage

The mats should be stored in a horizontal (flat) position. Up to 5 mats can be stacked on each other. Do not stack or pile a heavy load on top of the mats as this could lead to switch damage and premature failure. The mats should be stored in a dry environment at a temperature of -30 °C (-22 °F) to 60 °C (140 °F).

3. PRODUCT DESCRIPTION

3.1 Mat Shapes and Sizes

All ControlMat Safety Mats have the same general construction and operate on the same principle. This is described in detail in the next section of this document. Mats can be produced in any shape and size within the following restrictions:

- the maximum width of a mat is 48 inches (1200mm).
- the maximum length of a mat is 192 inches (4800mm).
- the maximum total area is 64 ft².

Protected areas that exceed these restrictions are covered with multiple-mat systems.

The dimensions of safety mats and their layout must be such that access to the machine is not possible without stepping on the active area of a mat. It should not be possible to move the mats or bridge them using boards, plates, etc.

3.2 Inactive Zone

ControlMat Safety Mats have an inactive zone around the outer edges. This inactive zone "D" is 1.25" wide, which means that the dimensions of the active zone (i.e., the zone within which the application of pressure will actuate the sensor) is 2 x D, or 2.50", less than the overall dimensions of the mat as shown in **Figure 1**. The active zone is defined as the area of the mat where a stated object size (the test piece) is guaranteed to be sensed 100% of the time. (See **Table 1**). This should be kept in mind when specifying the size of a mat for a particular application.

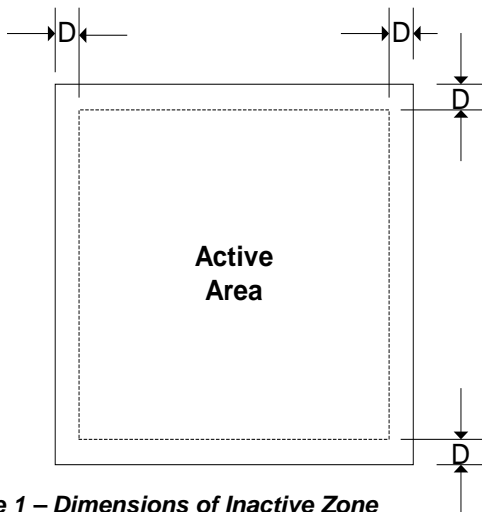

Figure 1 – Dimensions of Inactive Zone Around Outer Edge of Mat

Test Piece Size	Inactive Zone D
3.15" (80 mm)	1.25" (32 mm)

Table 1 – Test Piece and Inactive Zone

3.3 Lead Options

ControlMat Safety Mats have a number of lead options, depending on the application. Individual mats are usually supplied with a single 4-conductor cable. For applications requiring multiple mats, versions with either two 2-conductor leads or two 4-conductor leads are also available, so as to facilitate a "daisy chain" connection (or series connection) between them.

3.4 Edging Options

Individual mats are normally supplied with a ramped edge and can be secured with Type AE-1 aluminum edging. Mats can also be supplied with square edges for use with type AE-2 or AE-3 aluminum edging. This aluminum edging secures the mat, provides a wiring raceway, and has a ramped approach area to eliminate any tripping hazard.

4. TECHNICAL DESCRIPTION

4.1 System Overview

ControlMat Safety Mats are used to create a sensing area that may consist of a single mat or a combination of mats. When a person stands in this sensing area, a stop signal is transmitted to a safety interface control unit. Upon receiving a stop signal from the sensor, the control unit switches off its output relays causing dangerous motion to cease or be prevented.

4.2 Mat Design

4.2.1 Internal Construction

The construction of the ControlMat Safety Mat is shown in **Figure 2**. An array of Tapeswitch ribbon switches is sandwiched between two layers of matting material. The switching elements are connected in series and fastened to the top layer of the mat.

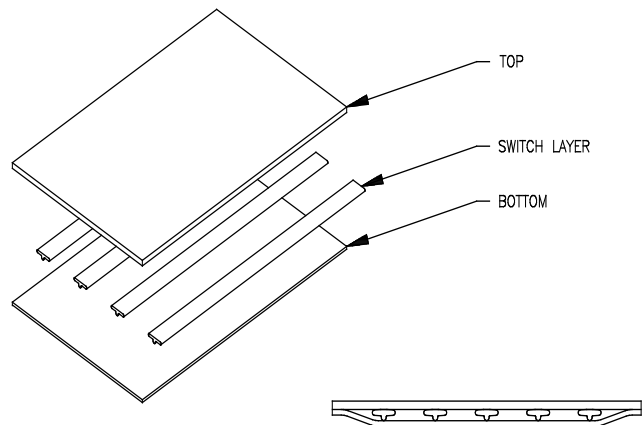

Figure 2 – Construction of a ControlMat

The top and bottom layers are constructed from a PVC-based heavy-duty ribbed matting material. This material features laminated construction and contains special additives and fillers to increase its abrasion and chemical resistance. It is formulated to withstand years of pedestrian traffic. The top sheet is 0.25 inch (6.5mm) thick and the bottom sheet is 0.19 inch (5mm) thick.

The construction of the ribbon switch sensors is shown in **Figure 3**. Each switching element is a long normally-open switch consisting of two copper plated steel conductors held apart at the sides by an insulator. When pressure is applied to the top of the switch, the two conductors are forced together, producing a contact closure.

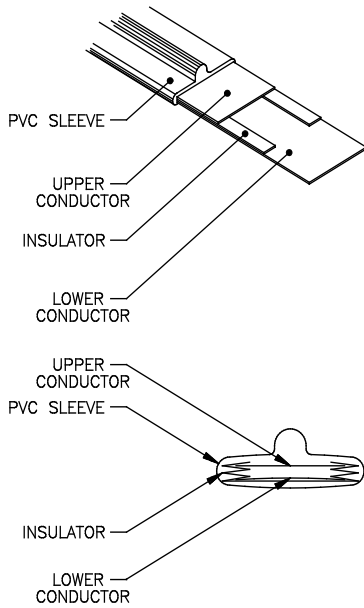

Figure 3 - Construction of Tapeswitch Elements

All the upper conductors of all the switch elements are connected together and all lower conductors are connected together, effectively creating a single normally open switch. The switches are self-bottoming and as a result they can withstand very high loads and repeated operation. A life of several million operations is typical.

4.2.2 Chemical Resistance

The PVC matting material is resistant to most chemicals commonly found in an industrial environment. Resistance to room temperature non-organic acids and alkalis is excellent, however, if hot or concentrated, these will cause deterioration with prolonged exposure. Resistance to aliphatic solvents is fair. Resistance to chlorinated and aromatic solvents is only fair to poor. Resistance to ketones and esters is poor. In general, the effect of deleterious fluids is related to the concentration and length or exposure.

Note that the effect of combinations of chemicals can be unpredictable and may warrant testing on a sample of the mat material. See **Table 2** for the chemical resistance to some common fluids.

Fluid	Mat Material
Water	Excellent
Alcohol	Excellent
Hydrochloric Acid	Excellent
Nitric Acid	Fair to Excellent
Sulphuric Acid	Fair to Excellent
Acetic Acid	Fair*
Gasoline	Fair*
Acetone	Poor
Benzene	Poor

* Exposure related. Effect depends on whether exposure is continuous, casual, or cleaned immediately.

Table 2

4.2.3 Combining of Sensors

When a number of safety mats are used in combination, they are connected together in such a way that the control unit “sees” a single normally-open switch. On each mat, one pair of leads can be considered to be the input and the other the output. When connecting a number of mats together the output of the first mat is connected to the input of the second mat, and so on. This leaves the input leads of the first mat and the output leads of the last mat available for connection to the control unit as illustrated in **Figure 4**.

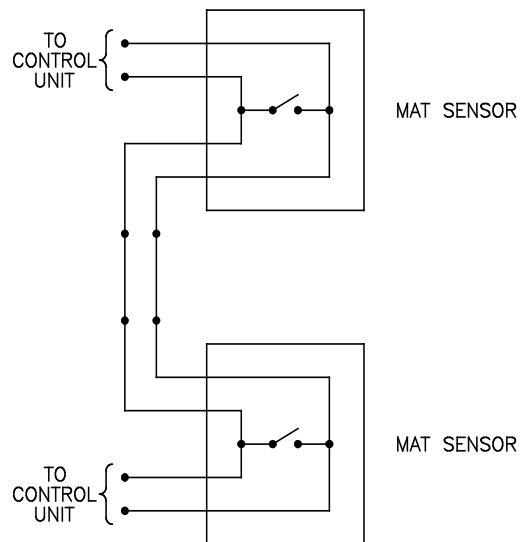

Figure 4 - Connection Scheme for Multiple Mats

5. MAT SIZE AND LOCATION

5.1 General Considerations

The dimensions of the mats and their layout must be such that the following conditions are met:

1. Access to the machine is not possible without stepping on a mat.
2. The machine must stop before a person can reach it after stepping on a mat.

In order to determine where the detection zone should start, it is necessary to consider the stopping performance of the machine.

Any machine, regardless of the efficiency of its braking system, will take a certain amount of time to come to rest after a stop signal is generated. From the instant a person's foot touches the mat to the instant that dangerous motion actually ceases is called the "overall system stopping time".

The dangerous parts of a machine will continue to move during this time. Therefore, the mat or mat system must be dimensioned such that the point at which a person first touches a mat is far enough from these dangerous parts that they cannot be reached before coming to a stop.

The worst case condition, as illustrated in **Figure 5**, where a person could be a full stride onto the mat before it is actuated, must also be taken into account. To summarize, the dimensions of the dangerous area to be protected depend on the specifics of each application. The parameters to be considered include:

- Speed of walk or arm movement.
- Arm length.
- Length of stride.
- Response time of system.
- Position of inactive zones.
- Overtravel of dangerous parts of the machine after a stop signal is generated.

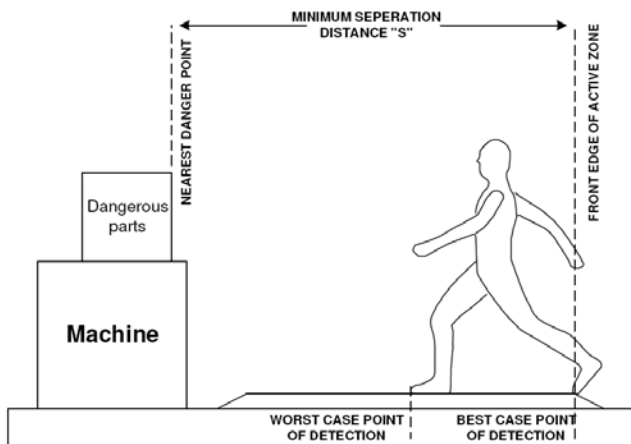

Figure 5 - Minimum Separation Distance

5.2 Minimum Active Distance

The key parameter in determining mat size and location is the **minimum active distance**, sometimes called the **minimum safe distance**. This is defined as the minimum allowable distance from the hazard to the leading edge of the detection zone. This minimum distance is calculated in accordance with a formula provided in safety standard EN999.

Note: For a machine that conforms to the harmonized European C-type standards, use the formulas or distances provided with the machine, rather than the EN999 formula given below.

5.3 Calculating Minimum Active Distance

The minimum distance formula for floor-mounted safety mats in millimeters as given in EN999 is:

$$S = (1600 \times T) + 1200$$

Where:

- S = minimum active distance (mm)
- 1600 = the approach speed (mm/s)
- T = the overall system stopping time (s)
- 1200 = stride length and arm reach (mm)

Note that the overall system stopping time, T, is given by the following calculation:

$$T = t1 + t2$$

Where:

- t1 = The maximum response time **in seconds** of the safety device between the actuation of the sensor and the generation of a stop signal to the machine. (Typically 0.030 seconds for a Tapeswitch controller.)
- t2 = The worst case elapsed time (in seconds) between the machine receiving a stop signal from a safety device and the dangerous parts coming to rest.

The overall system response time, T, should be measured several times and the highest value recorded. Also, a suitable allowance for brake deterioration should be added to this value.

The protected area should extend from this calculated minimum active distance to the base of the protected machine.

Note: To determine the overall size of the ControlMat required, add 3.5 inches to the calculated size, S, for a mat with AE-2 edging on both sides that would be traversed in approaching the protected machine. Increase this value to 4.00 inches if AE-3 edging is used.

5.3.1 Calculation Example:

Consider a machine with a worst case stopping time of 450 ms (0.450 s) and a controller with a response time of 30 ms (0.030 s).

First, calculate the overall system stopping time:

$$\begin{aligned} T &= t_1 + t_2 \\ &= 0.030 \text{ s} + 0.450 \text{ s} \\ &= 0.480 \text{ s} \end{aligned}$$

Then, calculate the minimum active distance:

$$\begin{aligned} S &= (1600 \times T) + 1200 \\ &= (1600 \text{ mm/s} \times 0.480 \text{ s}) + 1200 \text{ mm} \\ &= 768 \text{ mm} + 1200 \text{ mm} \\ &= 1968 \text{ mm} (77.5 \text{ in}) \end{aligned}$$

Thus, the active area of the mat must start at a distance of 77.5 inches from the nearest danger point and extend to the base of the machine.

For additional assistance in determining mat size, layout or mounting, for your application call Tapeswitch Corporation at **1-800-234-8273**.

6. INSTALLATION

This Technical Manual should be read in full before any installation work is attempted.

WARNING: *The Tapeswitch ControlMat is designed to protect operators working at or near dangerous machines. It can only perform that function if it is correctly installed and interfaced to a suitable machine controller or Safety Interface Module (SIM).*

It is the responsibility of the user to ensure that all persons involved in the installation of the product have the knowledge, training and experience necessary, and that they are fully conversant with all laws, rules, regulations and codes of practice pertaining to their task. This includes familiarity with the safety documents referenced on the title page of this manual.

6.1 General Information

The attention of the installer is drawn to following general requirements for the installation of a Tapeswitch Safety Mat System:

- (a) The machine must be electrically controllable.
- (b) It must be possible to stop the dangerous motion of the machine at any point in its operation, in any operating mode.
- (c) The control system as a whole must be designed to provide the level of safety integrity determined by the risk assessment.
- (d) Steps must be taken to prevent access to the dangerous parts of the machine from any direction not covered by the mat. Such steps could include fixed or interlocking fences or screens, additional
- (e) Steps must be taken to prevent a person from standing in the dangerous area without standing on the mat. The inner surfaces of fixed mechanical fencing should be designed such that there are no ledges or steps on which a person could stand and thereby avoid the mat. It may be necessary to fit additional mechanical barriers, covers etc. to cover any surfaces within the dangerous area on which a person could stand, such as the feet of the machine. Particular attention should be paid to the edge of the mat nearest to the machine. Ensure that a person tip-toeing at the front of the machine will still be standing on the active area of the mat. See **Figure 6**.
- (f) Wherever possible, rectangular mats of standard sizes should be used. Where this is not possible due to obstructions, mats with edge or corner cutouts, and even with holes, can be specified. This should only be done where the obstructions are permanent.
- (g) Under no circumstances should a mat be cut or drilled. It is not possible for the user to modify the size or shape of a mat.
- (h) Great care should be taken when handling mats. Never pick the mat up or drag it around using the cables. Never bend a mat at a radius less than 300 millimeters. Keep mats flat whenever possible. Always store mats flat. Mats with one edge longer than 1 meter should be handled by more than one person.
- (i) After installation the machine/mat system must be commissioned in accordance with Section 7 of this manual.
- (j) Any covers removed during installation must be replaced as soon as possible.

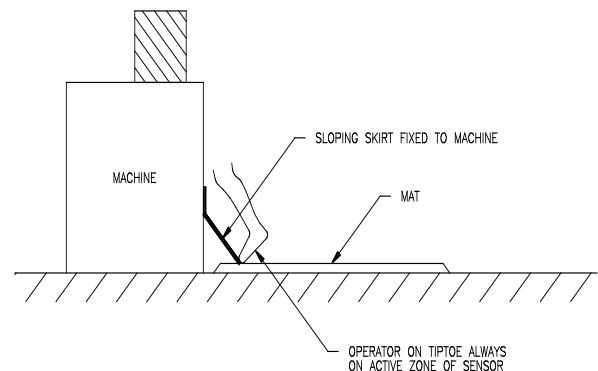

Figure 6 - Ensure Operator is Always Standing on Active Area of Sensor

6.2 Mat Installation

6.2.1 Mat Mounting Surface

The surface on which the mat is mounted must be sound and reasonably flat. The mat can tolerate minor irregularities but sharp edges or projections greater than 1/8" may cause false triggering or premature degradation. Where the surface is rough, cracked or breaking up, it should be treated using appropriate sealing and leveling compounds. Mats should not be mounted on corrugated or open diamond plate grating.

6.2.2 Edging Options

All mats should be fixed permanently in place, by using Tapeswitch aluminum edging. This is installed around the perimeter of the mat or system of mats. The edging choices are described below.

Type AE-1 Aluminum Edging

When installing a ControlMat Safety Mat with a ramped edge, the use of AE-1 aluminum edge is suggested to hold the mat in place, as illustrated in **Figure 7A**.

Installation of this edging is simple and straightforward. Align the edging strip with the ramped edge of the mat as shown. Affix the edging to the floor with appropriate fasteners spaced about 18" apart. Take care that the fasteners themselves do not present a trip hazard. Countersunk or low-profile screws are recommended.

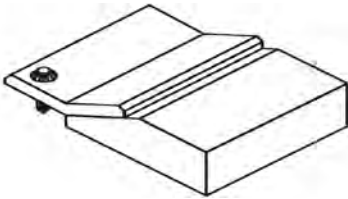

Figure 7A – AE-1 Aluminum Edge

Type AE-2 Aluminum Edging

This edging is used when mounting square-edged mats. It comes in two parts, a base and a cover. The cover provides a ramped approach to prevent a trip hazard at the outer mat edges. The base has a raceway that can accommodate the mat leads. This protects them from damage and acts as a conduit to route the wires.

Type AE-2 edging is illustrated in **Figure 7B**. The base is secured to the floor with anchor bolts and the top is secured to the base with self-tapping screws, as shown. This edging is mitered at the corners to maintain a ramped approach to the mat. The built-in wire raceway can accommodate two 4-conductor leads.

Type AE-3 Aluminum Edging

This edging is used when mounting square-edged mats, and is an alternate to Type AE-2. It includes corner pieces which eliminate the need for mitering and also provide convenient wire exit points. However, the built-in raceway can accommodate only one 4-conductor lead or two 2-conductor leads.

Type AE-3 edging is illustrated in **Figure 7C**. The base is secured to the floor with anchor bolts like Type AE-2. It has a cover made of yellow PVC instead of aluminum. This cover slides or snaps into place.

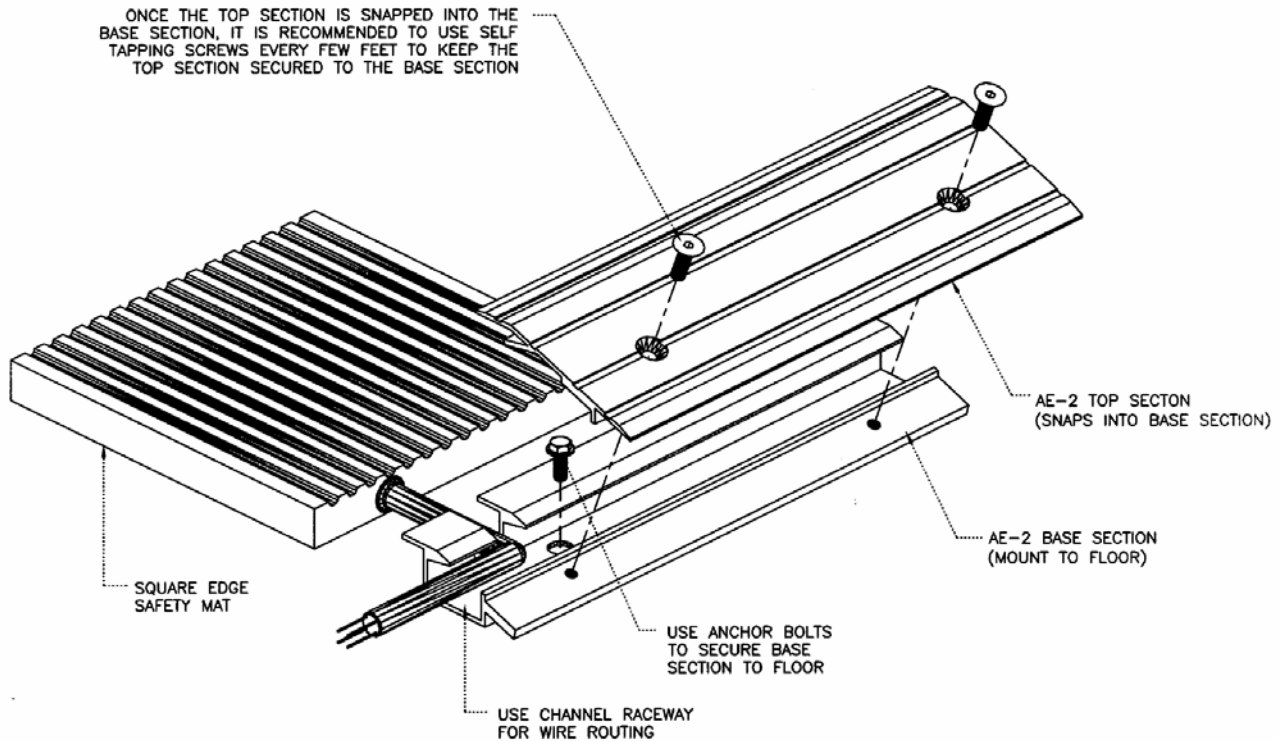

Figure 7B - AE-2 Aluminum Edge

AE-2 Installation Notes

1. Aluminum edge components are supplied as a 2-part assembly, consisting of a base and a top cover. The base is fastened to the floor to keep the mat from moving. It includes a raceway channel for routing the safety mat electrical leads. The top section provides a ramped edge to minimize the trip hazard and provides a cover for the wire channel.
2. The aluminum edges can be supplied pre-cut with mitered corners to fit the overall mat size. If not supplied, measure each side of the mat and cut the aluminum edge to fit. Use a 45° miter cut for corners and a 90° cut for joining straight lengths.
3. Position sensing mat where desired on a flat, clean floor with label side up and wire lead facing in correct orientation.
4. Center the aluminum edge on the mat, locate and drill a 0.344" hole through the vertical wall of the extrusion to accept wire lead from the sensing mat. Remove burrs and sharp edges from hole. Pull lead wire through and temporarily lay in recess. Anchor this edge in place per note 6. Use this side to bank all other sides.
5. Lay out remaining aluminum edges around mat. The edging lip is designed to sit on the mat surface, providing a seal against debris intrusion.
6. Once aluminum edge frame is laid out, check for squareness and install remaining anchor bolts. Anchorage to concrete is assumed. If otherwise, customer to provide suitable anchors. **Edging must be rigidly fixed to the floor.** Install anchors at approximately 18" intervals around the perimeter.
7. Route lead wire where desired. Cut a lead wire exit hole or notch in the aluminum cover.
8. Wire sensing mat into the system as required and check operation.
9. Place the aluminum covers into place on the base sections. Secure by snapping into place. It is recommended that the covers be secured to the bases with self-tapping screws as shown in **Figure 7B**.

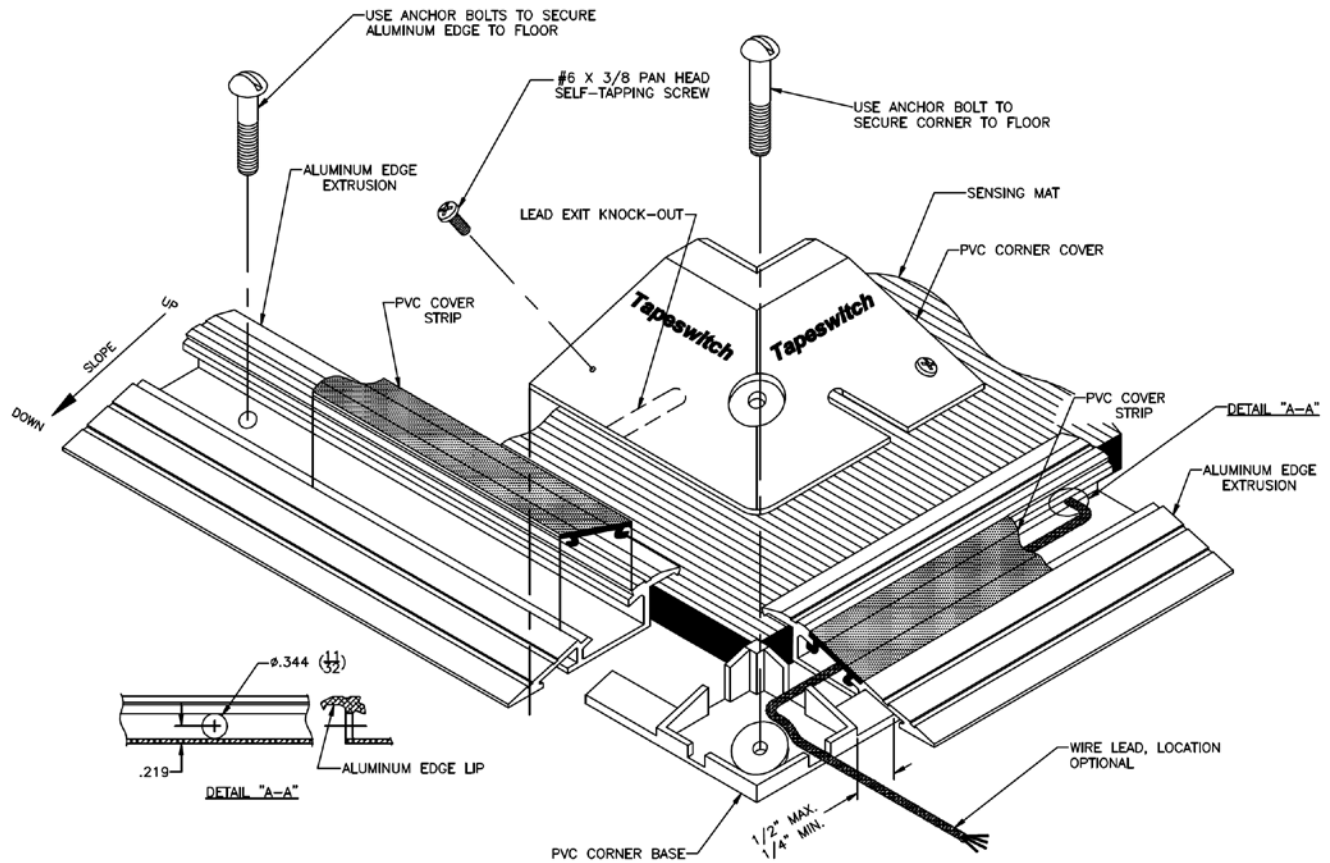

Figure 7C - AE-3 Aluminum Edge

AE-3 Installation Notes

1. Aluminum edge components can be supplied pre-cut $1/2$ " less than the nominal overall mat size. If not, measure mat side length, then cut aluminum edge to $1/2$ " less in length, i.e., $23-1/2$ " for a 24" mat, $35-1/2$ " for a 36" mat.
2. Position sensing mat where desired on a flat, clean floor with label side up and wire lead facing in correct orientation.
3. Center the aluminum edge on the mat, locate and drill a 0.344" hole through the vertical wall of the extrusion to accept wire lead from the sensing mat. See **DETAIL "A-A"**. Remove burrs and sharp edges from hole. Pull lead wire through and temporarily lay in recess. Anchor this edge in place per note 5. Use this side to bank all other sides.
4. Lay out remaining aluminum edges and PVC corner bases around mat. The edging lip (see **DETAIL "A-A"**) is designed to sit on the mat surface, providing a seal against debris intrusion. Gaps up to $1/2$ " are permitted at all corners where tongue mates with aluminum edge. If a slight interference occurs, trim the edging lip as required. This will be covered by the PVC corner cover.
5. Once aluminum edge frame is laid out, check for squareness and install remaining anchor bolts. Anchorage to concrete is assumed. If otherwise, customer to provide suitable anchors. **Edging must be rigidly fixed to the floor.** Install anchors at approximately 18" intervals around the perimeter. **Note: Do not install anchors at the corners until PVC corner covers are put in place.**
6. Route lead wire where desired. Lead wire may exit at any corner using the appropriate corner knockout. Use a utility knife to carefully scribe around knockout outline until it can be removed cleanly. Trim as necessary.
7. Wire sensing mat into the system as required and check operation.
8. Affix the yellow PVC cover strip into place. This can be done by inserting the upslope side first and tapping the downslope side with a soft face hammer or by sliding it in from one end. Notch the cover strip as required to clear lead wire. **Note: Once installed, the fill strips are subject to damage, if removed.**
9. Place the PVC corner covers into position. Align hole and secure each with an anchor bolt.
10. (Optional) Drill $7/64$ " holes at each pre-located center pointed on the corner covers and install a #6 x $3/8$ self-tapping screw to complete the installation.

6.2.3 Lead Wiring Options

ControlMat Safety Mats are usually supplied with a single 4-conductor lead. This configuration is suitable for both single-mat installations as shown in **Figure 8A**, and multi-mat installations as shown in **Figure 8B**.

For applications where multiple mats abut one another, a combination of mats with single and dual 4-conductor leads can often simplify and shorten the wire runs, as shown in **Figure 8C**.

For all models with 4-conductor leads, when the mat is stepped on, it produces a switch closure between the red and black leads and the yellow and white leads.

Occasionally, mats with two 2-conductor leads are used to facilitate a “daisy chain” connection between them, as shown in **Figure 8D**. In this case, the contact closure is between the black and white pairs.

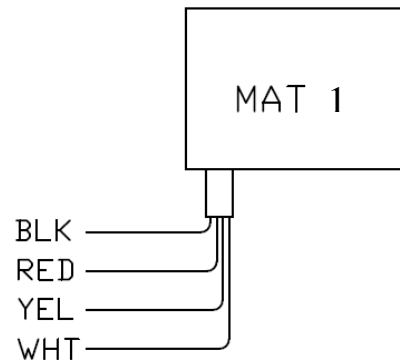

Figure 8A: Single Mat - Single 4-Conductor Lead

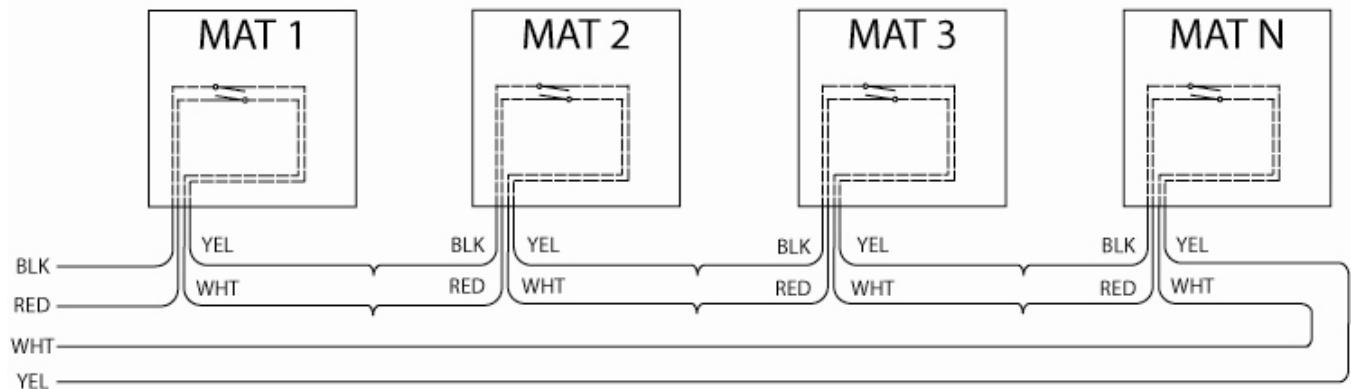

Figure 8B: Multiple Standard Standalone Mats – Single 4-Conductor Leads

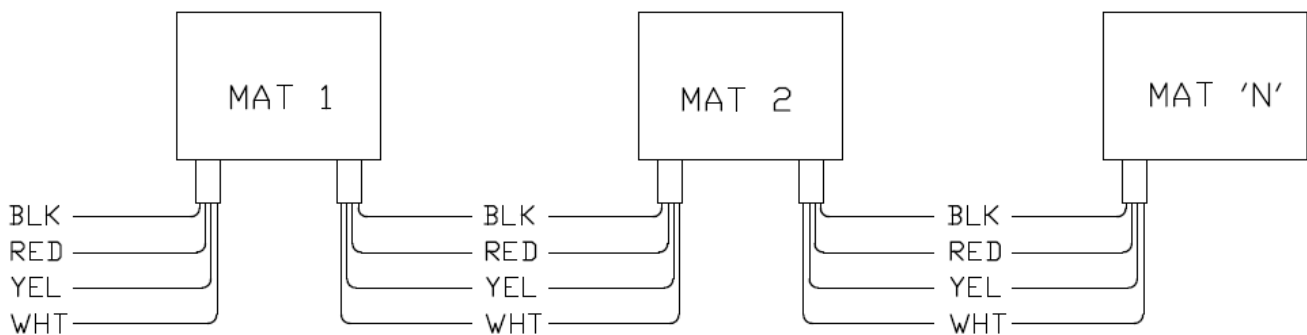

Figure 8C: Multiple System Mats – Single & Dual 4-Conductor Leads

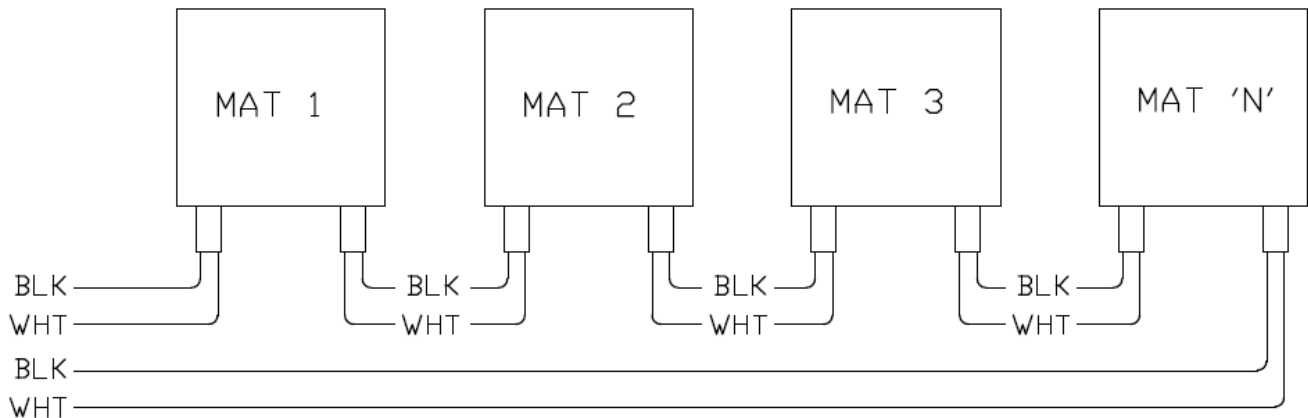

Figure 8D: Multiple System Mats – Dual 2-Conductor Leads

Note: In some cases, 2-conductor leads will be the same color and will have smooth and ribbed surfaces to distinguish them.

6.2.4 Installation Procedure

Step 1 - Plan the layout. Mark out on the floor the position and size of each mat. Take care to use the overall mat dimensions and take the inactive zones into account. Put the mat(s) in place. **Note that the mat(s) must be installed with the label side up.**

Step 2 - Cut all edging to size. Remove any burrs and sharp edges with a file.

Step 3 - Mark the positions of the mat leads and cut slots in the inner face of the edging base extrusion to allow access for them.

Step 4 - Position the edging base sections around the mat. Drill pilot holes through each base section for securing to the floor, if applicable. Remove the base sections and drill and plug the floor. Refit the base sections and secure them in position with screws, ensuring that the leads exit neatly through the slot(s) in the base section.

Step 5 – In an application where multiple mats are used to protect an area, they must be connected together. Refer to **Figures 8B thru 8D**. If necessary, cut the cables to length to facilitate the required interconnections. Always leave some slack in the cables so that a mat can be disconnected and reconnected at a later date, if service or maintenance is required.

Note that for multi-mat installations Type AE-3 channel can only be used with the wiring configurations shown

in **Figures 8C and 8D**. In the case shown in **Figure 8D**, the 4-conductor leads must be butt-spliced to fit in the built-in raceway

Step 6 - Route the cable(s) to the control unit. The cable(s) should exit from the edging as close to the control unit position as possible. The cables should be protected in suitable conduit between the edging and the control unit. Protect any edges over which the cables pass with grommet strip or similar.

Step 7 - Install the cover extrusion of the edging. Use suitable self-tapping screws for AE-2 edging. For AE-3 edging, the cover slides or snaps in.

7. COMMISSIONING CHECKS

The commissioning checks should be carried out by persons who are competent and who have access to all the information supplied with the machine and its safety equipment. The results of the examination should be recorded and the user and the employer of the person performing the examination should keep copies of this record.

The person carrying out the examination should, as a minimum, perform the following checks:

- a. Check that the ControlMat Safety Mat is suitable for use in the application.
 - i.) Check that the level of safety integrity provided by the ControlMat Safety Mat is suitable for the level of risk presented by the machine.

- ii.) Check that the environment is suitable for the use of the ControlMat Safety Mat.
- b. Check that the dimensions and position of the ControlMat Safety Mat are correct, taking into account the operating mode. For this purpose it will be necessary to check the overall system response time using a device designed for this purpose.
- c. Check that adequate measures have been taken to prevent access to the dangerous parts of the machine from any direction not covered by the ControlMat Safety Mat.
- d. Examine the machine controls and interconnection wiring to the ControlMat Safety Mat and ensure that all connections are correctly and securely made.
- e. Check that the ControlMat Safety Mat is fixed in position and that no trip hazards are present within the dangerous area.
- f. Check that it is not possible to stand in the dangerous area without actuating the ControlMat Safety Mat.
- g. Check that it is not possible for the dangerous parts of the machine to be set in motion while the ControlMat Safety Mat is actuated.
- h. Check that actuation of the ControlMat Safety Mat during a dangerous phase of operation (of the machine) results in the dangerous parts being arrested, or where appropriate, assuming an otherwise safe condition, before any part of a person could reach them.
- i. Check that after a machine has been stopped by the actuation of the ControlMat Safety Mat, it is not possible for the dangerous parts to be set in motion until the ControlMat Safety Mat has been cleared, a reset button has been operated and released, and the machine start control has been re-operated.
- j. Check that the removal of power from the ControlMat Safety Mat prevents further operation of the machine. It should not be possible for the dangerous parts of the machine to be set in motion until power has been restored, the reset button has been actuated and released, and the machine start control has been actuated.
- k. Check that ControlMat Safety Mat operates over the whole active area by walking, 'heel to toe' over the whole area in two directions as shown in **Figure 9**.

- l. Examine the stopping performance monitor (if installed) to ensure that it is installed and functioning correctly. Ensure that the means by which the stopping performance can be assessed by the operator is indicating correctly.
- m. Test the muting arrangements (if installed). Ensure that the muting is only possible during non-dangerous operation and ensure that the safety level of the muting device is at or above that of the safety mat but never below.
- n. Examine brakes and clutches (if installed) as recommended.

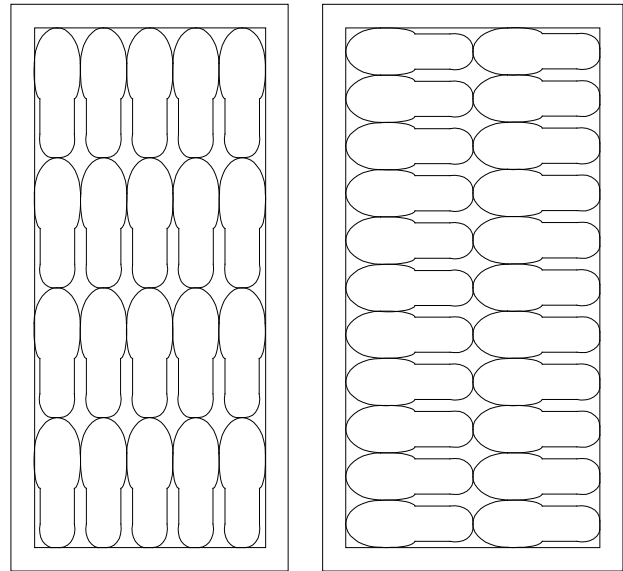

Figure - 9

8. CLEANING AND MAINTENANCE

Once installed and interfaced to a machine, the ControlMat Safety Mat will be an active safety sensor. It will actuate each time the active surface is stepped on.

Daily work on the ControlMat Safety Mat by one or several persons will not lead to any deterioration of the performance.

The ControlMat Safety Mat does not require any periodic maintenance, however, its life will be considerably increased if a basic cleaning routine is observed.

The surface of the mat should be swept clean daily to remove dust and dirt. Since grease and oil can cause the mat to become slippery, spills should be removed immediately or covered with sawdust, and then be removed at the next daily cleaning.

The frequency of general cleaning depends on the nature of the environment. In relatively clean environments, where the mat is rarely exposed to water or other fluids, monthly cleaning is usually sufficient. In dirtier environments, clean weekly or more frequently, as required.

WARNING: Servicing of ControlMat Safety Mats should only be carried out by qualified personnel. Servicing involves the exposure of terminals and devices that carry potentially lethal voltages. Only those persons with the appropriate training and experience should undertake this work. If there are any questions call Tapeswitch Corporation at **1-800-234-8273**.

IMPORTANT after any part of the system has been replaced, the installation should be considered as new and, as such, should be re-commissioned in accordance with this manual.

The ControlMat Safety Mat has no user repairable parts. If a mat or a part of a mat needs repair, contact Tapeswitch Corporation at **1-800-234-8273**.

9. SPECIFICATIONS

- 1) **Inactive Zone:** The area of the mat defined in *Figure 1* and *Table 1*, plus the width of any extruded aluminum edging.
- 2) **Sensor Switch:** Ribbon switch devices consisting of a pair of metal conductor plates with an extruded jacket of soft PVC.
- 3) **Lead Wires:** One or two 4-conductor cables, each comprised of 4 separate 18 AWG color-coded PVC-insulated conductors (black, white, red, and yellow), wrapped in a durable, black PVC jacket.
Optional: Two 2-conductor lead cables comprised of 22 AWG white and black color-coded PVC-insulated conductors. The nominal diameter of the cable is 0.19 inches.
- 4) **Surface Material:** Ribbed Koroseal® Matting on top and bottom surfaces.

For additional specifications, see *Table 2*.

Requirement Grade		EN 1760-1 and EN 954-1 Category Rating: To Maximum Category 3. See controller rating.
Power Consumption		6 VA (with PSSU Series Controller)/5 VA (with PRSU Series Controllers)
Response Time		<25 ms
Rated Life		3 million operations
Actuating Force		22 lb nominal with 50 mm test piece < 66 lb with 80 mm disc
Temperature Range	Operation	0 to 50 degrees C
	Storage	-20 to 70 degrees C
Protection Rating		IP65
Inactive Zone		See Figure 1 and Table 1
Recommended Operating Voltage		24 Vdc or Vac at 1.0 amp or less
Weight (approx.)		3.5 lb/ft ² (17 kg/m ²)
Safety Standards		UL and cUL Recognized; EN 1760-1 TUV CE Approved

Table 2- General Specifications

10. TROUBLESHOOTING GUIDE

In a properly wired and installed safety system, the safety interface module or controller will prevent the protected machine from operating if the mat has an internal open or shorted connection. If you suspect there is a problem with a mat, follow the appropriate procedure below to track down a faulty condition.

All testing can be done with a continuity meter. Before testing a mat, disconnect all four wires, so it is completely isolated from the system.

10.1 Mats with a Single 4-Conductor Lead

Test continuity in accordance with the table below. Measure between the wires in each pair and confirm the proper result. Test the mat with and without a person standing on it.

Pairs to Test	Mat State	Proper Result
Black and Yellow	Not applicable	Less than 5 ohms
Red and White	Not applicable	Less than 5 ohms
Red and Black	No weight	Open circuit
Red and Black	Occupied	Less than 5 ohms
Yellow and White	No weight	Open circuit
Yellow and White	Occupied	Less than 5 ohms

Continuity Table for Mat with Single 4-Conductor Lead

10.2 Mats with Two 4-Conductor Leads

Test continuity in accordance with the table below. Measure between the wires in each pair and confirm the proper result. Test the mat with and without a person standing on it.

Pairs to Test	Mat State	Proper Result
Black and Black	Not applicable	Less than 5 ohms
Red and Red	Not applicable	Less than 5 ohms
Yellow and Yellow	Not applicable	Less than 5 ohms
White and White	Not applicable	Less than 5 ohms
Red and Black (Either pair)	No weight	Open circuit
Red and Black (Either pair)	Occupied	Less than 5 ohms

Continuity Table for Mat with Two 4-Conductor Leads

10.3 Mats with Two 2-Conductor Leads

Test continuity in accordance with the table below. Measure between the wires in each pair and confirm the proper result. Test the mat with and without a person standing on it. Note that the lead pairs may be black and white or ribbed and smooth, depending on the model.

Pairs to Test	Mat State	Proper Result
Black and Black or Ribbed and Ribbed	Not applicable	Less than 5 ohms
White and White or Smooth and Smooth	Not applicable	Less than 5 ohms
Black and White or Ribbed and Smooth (Either pair)	No weight	Open circuit
Black and White or Ribbed and Smooth (Either pair)	Occupied	Less than 5 ohms

Continuity Table for Mat with Two 2-Conductor Leads