

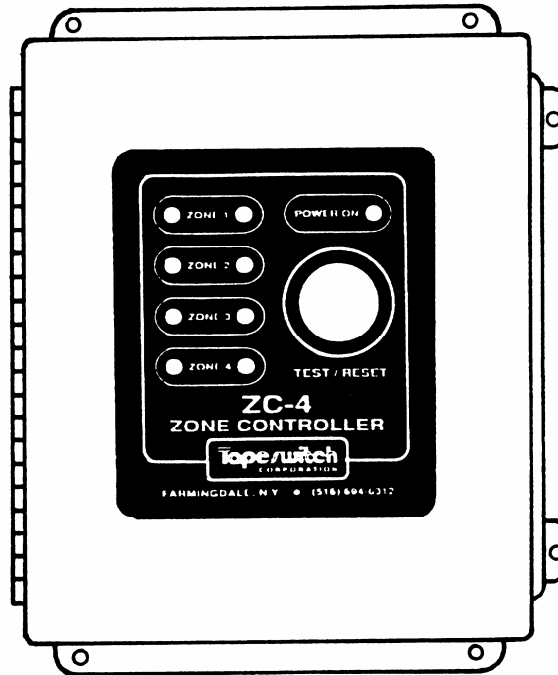

ZC Series Zone Monitoring Controllers Installation Instructions



MANUAL Reset Controllers		
Model	Description	Part Number
ZC-1	1 Zone Controller	0421
ZC-2	2 Zone Controller	0422
ZC-3	3 Zone Controller	0423
ZC-4	4 Zone Controller	0424
AUTO Reset Controllers		
ZCA-1	1 Zone Controller	0431
ZCA-2	2 Zone Controller	0432
ZCA-3	3 Zone Controller	0433
ZCA-4	4 Zone Controller	0434

CONTENTS

1. INTRODUCTION	<u>Page</u> 2
2. PRINCIPLES	3
ZONE SENSING	
RESET LOGIC	
OUTPUT CONTACTOR	
3. APPLICATIONS	4
4. INSTALLATION	5
5. OPERATIONS	6
BASIC OPERATION	
DAILY TESTING	
SHUTDOWN	
LOCKOUT OR TAGOUT	
6. SERVICING	6
TROUBLESHOOTING	
PARTS REPLACEMENT INFORMATION	
TECHNICAL SPECIFICATION	

1. INTRODUCTION

Tapeswitch ZC Series zone controllers are versatile, easy to install electrical controls, made for industrial applications and duty. They simplify the interfacing of conventional sensing switches to industrial systems. Tapeswitch controllers feature:

- Low voltage DC sensing circuits.
- One, Two, Three, or Four independent sensing zones for monitoring multiple sensing switches.
- Continuous, independent zone monitoring; no scanning.
- Multi-sensor interfacing - NO (Normally Open), NC (Normally Closed), and supervised FAIL-SAFE (four wire) sensing contacts can all be used.
- Individual zone indicators for easy troubleshooting.
- Hefty load contactor, up to 25 amps. Handles industrial voltages, up to 600V AC.
- Single Phase or Three Phase load capability.
- A complete, pre-wired package, ready for use in a heavy steel enclosure. National Electrical Manufacturers Association (NEMA 12).

Tapeswitch controllers are ideal for use with Tapeswitch ControlMats, Armor Mats, Diamond Plate Mats, CVP style Control Mats, Controflex ribbon switches, or Tapeswitch sensing edges. These sensors are frequently in contact with the ground, or are manually actuated. The controller provides 24 Vdc for sensor operation, which is considered non-hazardous in accordance with the National Electrical Code (NEC), and there are no Radio Frequency Interference (RFI) or capacitive coupling problems with direct current.

FAIL-SAFE supervision is an additional feature of Tapeswitch zone controllers. When properly connected to a FAIL-SAFE Switch, the load contactor will de-energize on loss of power to the controller, activation of the sensor, a short in the sensor or sensor wiring or a break (open) of the sensor or sensor wiring.

WARNING:

AUTO Reset models are NOT to be used for primary safety applications. See additional cautions inside this manual. Improper application of an AUTO Reset controller may result in death or serious injury to personnel.

2. PRINCIPLES

The basic function of these controllers is to turn off or on a single powerful machine in response to low power, low voltage inputs. One load circuit is controlled, based on sensing switches connected to the different zone inputs. Depending on the model selected, there may be one, two, three, or four independent input zones. A 'RESET' input will re-energize the machine after a fault is removed.

Two versions of each model are available, depending on the application. In the Manual reset model, a specific reset signal is needed to initiate output. In the AUTO reset model, no signal is needed, and an output is initiated whenever all zones are fault-free. *Figure 1* shows a four zone, manual reset model.

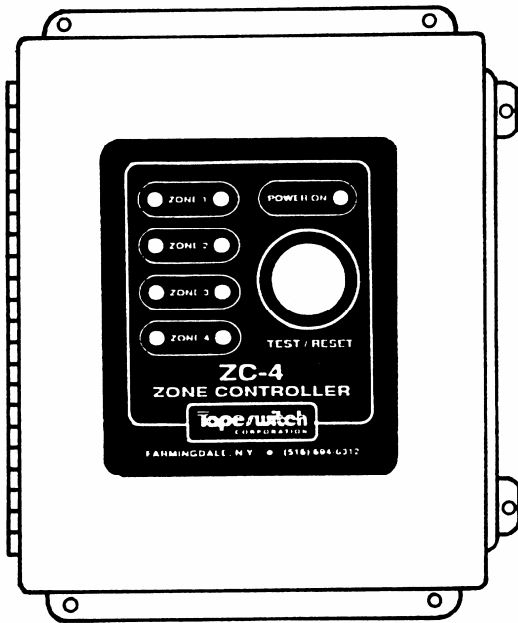

Figure 1 – Front Panel of manual reset ZC-4

All models of the ZC Series controllers are packaged in a NEMA 12 wall-mount enclosure. Mounted internally on the enclosure door is an LED circuit board which holds the indicating lamps. In the main part of the enclosure, a subpanel holds the main or 'zone' printed circuit board, power transformer, and output contactor. *Figure 2* shows the internal arrangement of a ZC-4.

Zone controller operation is divided into three functions: zone status monitoring, reset logic, and output contactor operation.

ZONE SENSING

Zone sensing takes place continuously. Each zone is independently monitored by a low-voltage DC current loop circuit. When the zone is clear and fault-free, the zone status light is green. However, a red status light will show

(and the controller will trip) upon any of the following conditions:

- Loss of power to the controller
- Activation of the switch in that zone
- A short in the sensor or sensor wiring for that zone
- A break (open) of the sensor or sensor wiring for that zone

RESET LOGIC

The reset logic acts to energize and de-energize the output contactor. The reset logic continuously checks zone status, and the reset command signal. When all zones are clear and fault-free, and the reset signal is received, the contactor is energized. In a manual system, there must be a separate reset signal, usually from the front panel push button. An AUTO Reset Model requires no separate signal, and resets whenever the zones are clear and fault-free.

Both the reset logic, and zone monitoring logic components are located on the 'Zone PCB' inside the cabinet. *Figure 2* shows the typical layout of the inside of a four zone controller.

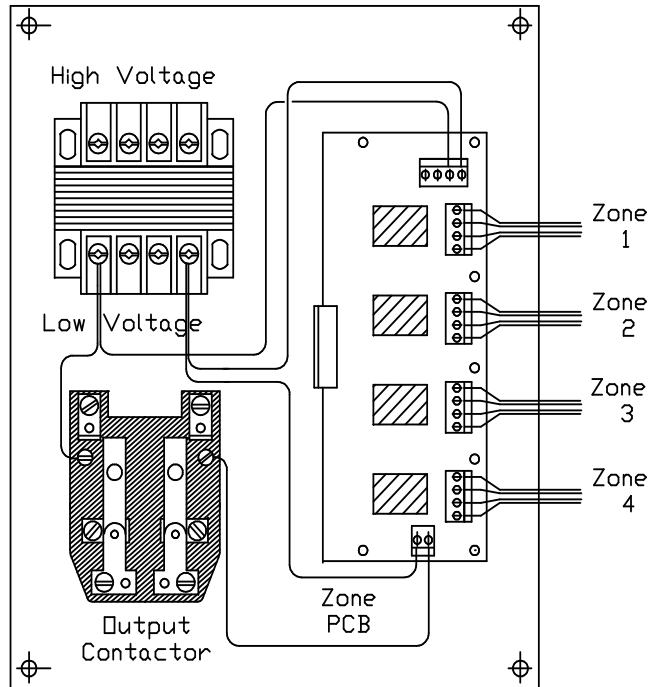

Figure 2 - Internal Arrangement of a ZC-4

Because an AUTO Reset controller causes the output action without further operator involvement, it is ideal for machine automation. For example, a typical application uses an industrial duty ControlMat to open a small door on a reheating furnace. A worker carries a part to the furnace using two handed tongs. The door opens automatically when the worker steps on the mat. Operator safety is not involved.

When safety is involved, only the manual reset controller should be used. Machine operation based on operator presence-sensing is a dangerous application, forbidden by OSHA in most instances. An example of a dangerous AUTO Reset application would be a safety mat used in front of an NC punch press. The mat only causes the press to halt while the operator is on the mat. One worker was injured when he stepped off a mat, onto the bed of a press to clear a jam. When the jam cleared, the bed continued its movement, pinning the worker. If the control had been Manual Reset, the accident would not have occurred.

WARNING:

Do not use an AUTO Reset control in a safety application. Serious death or injury may result, particularly during unexpected operations or during maintenance.

OUTPUT CONTACTOR

Each ZC Series controller houses a small, high-power contactor, suitable for switching machine loads up to about 1.5 HP. The output contactor is designed to handle a single machine load. It is located on the lower left of the main internal panel, as shown in *Figure 2*.

3. APPLICATIONS

Section Two of this manual discusses the primary safety considerations in selecting a Manual or Auto Reset controller. Be sure you are familiar with the concepts presented before applying a controller to a specific machine.

The ZC Series controllers let you configure a sophisticated array of sensors to control a single machine. When multiple sensors are used, a frequent problem is the difficulty in troubleshooting even a simple fault. Dividing the sensors into zones and monitoring each zone independently, greatly reduces downtime and troubleshooting. The ZC Series provides 1 to 4 independent zones. For custom systems with even more zones, contact TAPESWITCH.

Each sensing zone may be connected in any of three different wiring arrangements. A NO contact, a NC contact, or a four wire FAIL-SAFE switch may be connected to each zone. *Figures 3, 4, and 5* show the specific configuration to use when connecting each type of sensor.

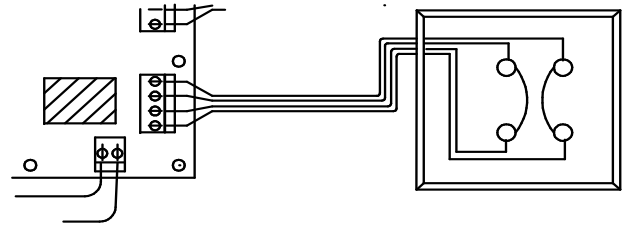

Figure 3- Connecting a Tapeswitch FAILSAFE sensor

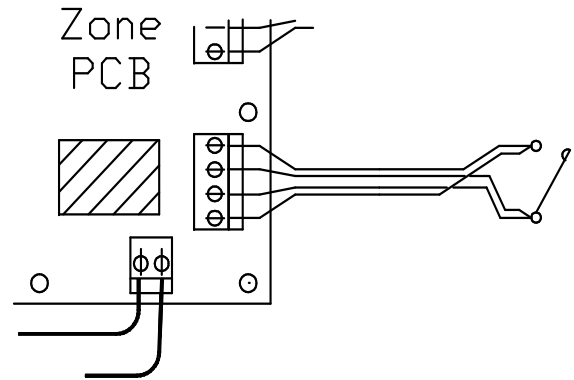

Figure 4 - Connecting an NO switch

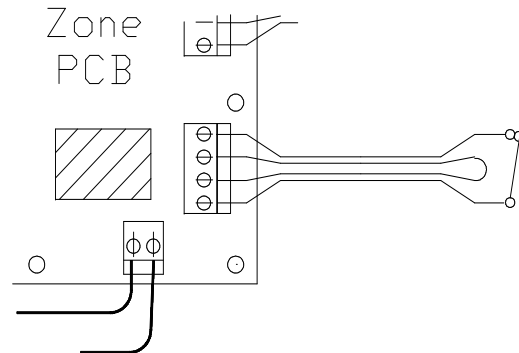

Figure 5 – Connecting an NC switch

Connecting multiple sensors on a single channel makes troubleshooting more difficult and for that reason is NOT recommended. TAPESWITCH recommends that no more than two mat type sensors ever be used for a single zone. Never bypass or disconnect a zone. Troubleshoot the system by substituting components. If more, or fewer, zones are needed, install a Tapeswitch controller with the correct number of zones.

All channels are configured for FAIL-SAFE operation as shipped. (User-supplied jumpers must be used to reconfigure for other contact types). Note that the NO connection is not supervised and should be avoided in some applications.

CAUTION

Consult the technical data for each sensor being used to determine maximum units in a configuration, operating limitations and other requirements.

Observe the polarity shown. This means that terminals 1 & 4 and 2 & 3 respectively must be connected to the same continuous conductor. Tapeswitch FAIL-SAFE sensing switches are coded to indicate polarity.

The load contactor has both NO and NC contacts. It can be used to switch both legs of a single phase load. It is recommended that both legs be switched. A three phase load contactor is optionally available.

WARNING:

NEVER switch the electrical ground. Never switch only the neutral on a single phase load.

WARNING:

Some particularly hazardous equipment, such as power presses, require specific levels of reliability, even when a fault occurs to the controller. Be sure to check applicable ANSI and OSHA documents for specific requirements. Tapeswitch ZC and ZCA controllers are not single-fault-tolerant. Contact Tapeswitch for information on multi-zone, multi-channel controllers.

4. INSTALLATION

When used to guard a hazardous location, the controller must be a manual reset type, and be located in a safe area, away from any hazards being guarded. This is common sense. The operator should never be able to re-energize the controls while in a hazard area. If the controller is best located in a hazard area, then disconnect the front panel "RESET" switch internally, cut off the connector, and substitute a NO push button switch which is located in a safe area. Use terminals 701 and 702 on the PC board.

These industrial controllers are designed for permanent hard-wired installation. They must be securely mounted. (There are predetermined locations for mounting hardware on the rear of the controller). Mounting brackets are standard with each controller. The enclosure is rated NEMA 12, which means dust and water resistant. This is suitable for most indoor locations.

All supply, zone sensing, and load wiring must be in accordance with the NEC. Refer to the Technical Specifications (Section 2) for data on permissible loads.

CAUTION:

Observe the NEC when wiring Tapeswitch controllers, specifically Articles 300 and 310. Be sure that all wiring is properly sized for the load by referring to Table 310-17. Be sure to connect the supply voltage to the contactor common terminals and the load to the NO or NC terminals. Failure to adhere to the NEC may result in serious fire or injury.

High Voltage - Electrocutation Hazard. Live power may be present on the transformer. Be sure that the unit is voltage-free before installing or servicing.

TAPESWITCH ControlMats, ArmorMats, and other sensing devices are color-coded to show polarity. *Figure 6* shows typical color coding for a Control Mat.

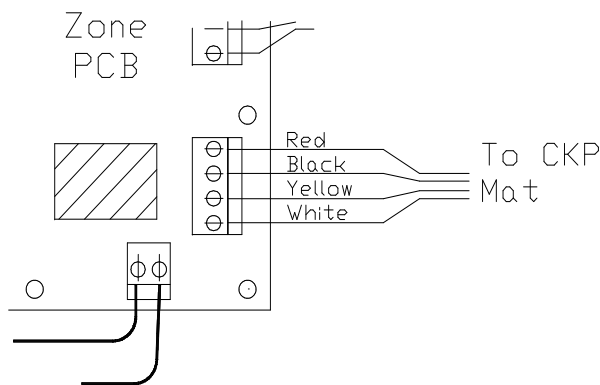

Figure 6 – Typical color code for ControlMats

Power (120 or 240 Vac) must be supplied to the controller. Connect incoming power to the high voltage side of the transformer. See *Figure 2*, and the diagram on the side of the transformer. Power requirements are low, usually much less than the 20 VA specified. If a 120 Vac load is to be connected directly to the controller, insure that supply wiring is properly sized to supply both load and controller.

CAUTION

Never try to convert a Manual RESET controller to AUTO Reset operation. Damage to the controller will result.

For 120 Vac operation, connect H1 to H3, and connect H2 to H4 on the transformer. For 240 Vac operation, connect H2 to H3 only.

5. OPERATIONS

CAUTION:

Be sure the controller has been properly connected before attempting to operate the unit.

BASIC OPERATION

START UP: Turn on the power. The green power lamp should light. All red indicator lamps should come on and remain lit. This indicates that the zones have not been 'RESET'. (The AUTO reset version may switch from red to green).

MANUAL RESET: Push the red 'RESET' button. All red and green lamps should come on and remain on until the button is released. If any lamp does not come on, it indicates a defective lamp or control channel. If the zone switches are fault-free, the load contactor will energize with a sound easily heard outside the cabinet.

Release the red 'RESET' button. The red lamps will go out and the green lamps will remain on for all zones with fault-free sensing circuits. If any zone is not clear, its red lamp will stay lit, and the load contactor will not energize.

DAILY TESTING

Upon startup each day and prior to resetting the controller, test the lamps, and test each zone by actuating the appropriate sensing switch. On an AUTO reset model, do not energize the load until the zones have been tested.

LAMP TEST: Press the red 'RESET' button at any time to test the lamps. All lamps should light. **NOTE:** This will not affect the state of an energized load contactor. (For auto reset, activate each zone separately to test).

SHUTDOWN

Simply turn off power to the Tapeswitch controller. The load contactor will de-energize. The load contactor can also be de-energized by activating one of the zone sensing switches.

LOCKOUT OR TAGOUT

OSHA regulations (29CFR Part 1910.147). The control of Hazardous Energy (lockout/tagout) final rule will be enforced on or after January 2, 1990. This standard requires employers to develop and utilize an energy control program to prevent the unexpected energization or start up of machines and equipment during service and maintenance operation. Formal employee training and written documentation is required. *There is no provision for lockout at this controller.*

6. SERVICING

TROUBLESHOOTING

The following steps will usually isolate any problems in a ZC Series zone controller system:

- De-energize the load until the controller has been checked out.
- Check that all wiring is secure and proper.
- Energize the controller only. Check for 120/240 VAC to 'HIGH VOLTAGE' terminals. Be sure connections are correct!
- Check that a lamp comes on in each zone when power comes on. If none light, the power transformer, or rectifier, may be defective, or there may be loose internal wiring.
- If only a few zones show lights at power on, it indicates problems in the zones which show no lamp. The controller's logic board should be replaced.
- Manual reset only. If, at power on, all lamps light and the load contactor energizes, it indicates a short on the 'RESET' lines, which must be located and corrected! Operation with a continuously closed 'RESET' circuit will damage the controller.
- Check the sensor wiring by pushing and releasing the 'RESET' button. The red lamps should all go out, and the load contactors should energize. If some zones will not reset, check the sensors on these zones. If necessary, disconnect sensor wires, and install a known good FAIL-SAFE four wire switch. If the zone still fails to 'RESET', it indicates a defective zone relay, which may be tested by exchanging controller's logic boards.

PARTS REPLACEMENT INFORMATION

Part Description	Model	Part Nr.
LED Circuit Board (AUTO Reset uses the same part as the manual reset listed here)	ZC-1	13488
	ZC-2	13489
	ZC-3	13490
	ZC-4	13491
Zone Circuit Board, Manual Reset models	ZC-1	13473
	ZC-2	13463
	ZC-3	13464
	ZC-4	13462
Zone Circuit Board, AUTO Reset models	ZCA-1	
	ZCA-2	
	ZCA-3	
	ZCA-4	
Main contactor	All	11001
Transformer	All	11016

Replacement parts, additional controllers, and technical assistance are all available through Tapeswitch, and through industrial automation distributors throughout North America, Europe, and Asia. Contact Tapeswitch for the name of the sales group nearest to you.

TECHNICAL SPECIFICATION

ITEM	RATING	UNITS
Power Required	120 or 240	VAC
	50/60	Hz
	20	VA
Enclosure	NEMA 12	
Color	Beige	
Sensor Voltage	24	VDC
Load Capacity	10 Amp @ 600 VAC, max non-inductive	
	12 Amp @ 480 VAC, mzx non-inductive	
	25 Amp @ 117 VAC, max non-inductive	
	2 HP motor @ 120-600 VAC maximum	
Reset Signal	NO to NC to NO contact, manual reset models only	

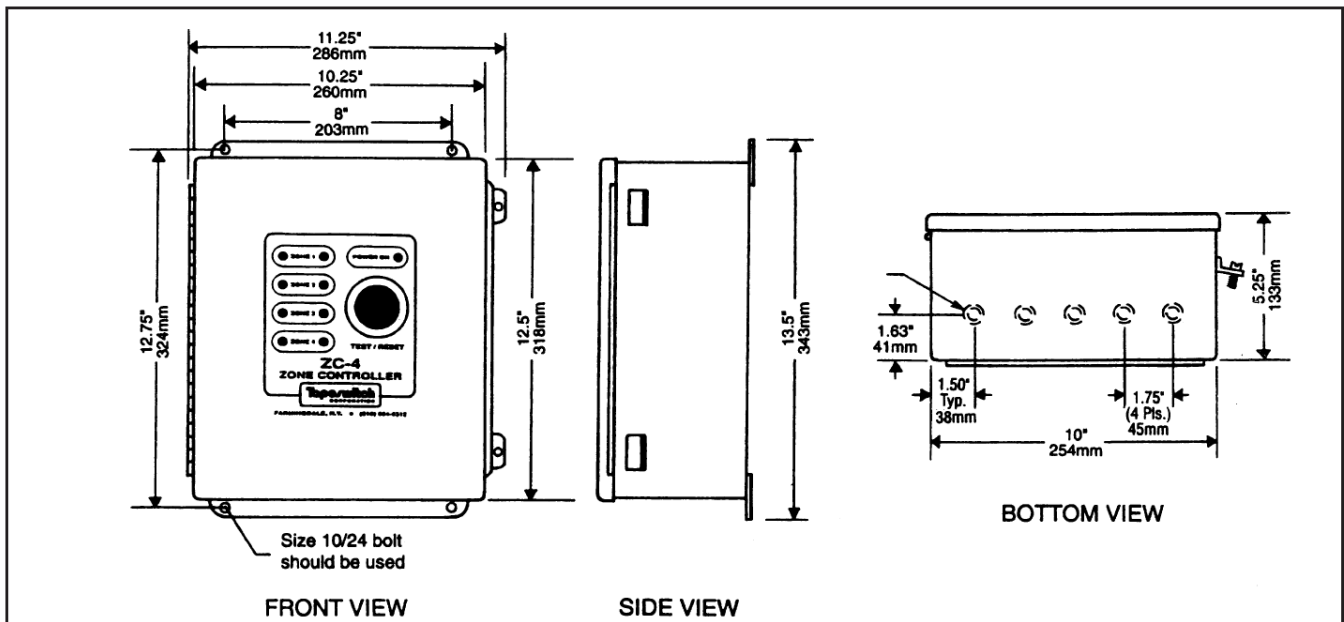

Figure 7 – ZC Series Dimensions